



Overload Control Practices in Eastern and Southern Africa

Main Lessons Learned

Michael Ian Pinard



Overload Control Practices
in Eastern and Southern Africa

Main Lessons Learned

Overload Control Practices in Eastern and Southern Africa

Main Lessons Learned

Michael Ian Pinard

April 2010



Sub-Saharan Africa Transport Policy Program

The SSATP is an international partnership to facilitate policy development and related capacity building in the transport sector in Sub-Saharan Africa.

Sound policies lead to safe, reliable, and cost-effective transport, freeing people to lift themselves out of poverty and helping countries to compete internationally.

* * * * *

The SSATP is a partnership of

- 35 SSA countries
- 8 Regional Economic Communities
- 2 African institutions: *UNECA, AU/NEPAD*
- Recent and current donors: *European Commission (main donor), Austria, Denmark, France, Ireland, Norway, Sweden, United Kingdom, Islamic Development Bank, African Development Bank, and World Bank (host)*
- Many public and private national and regional organizations

* * * * *

The SSATP gratefully acknowledges the financial contributions and support of the European Commission; the governments of Austria, Denmark, France, Ireland, Norway, Sweden, and United Kingdom; and the Islamic Development Bank, the African Development Bank, and the World Bank.

* * * * *

More publications on the SSATP Website:

www.worldbank.org/afr/ssatp

The findings, interpretations, and conclusions expressed here are those of the author and do not necessarily reflect the views of the SSATP or its partners.

© 2010 The International Bank for Reconstruction and Development / The World Bank

All rights reserved.

TABLE OF CONTENTS

Foreword	vii
Acknowledgements	ix
Acronyms	xi
Key map	xiii
Executive summary	xv
Way forward	xxv
1. Introduction	1
Project background	1
Goal and objective of the project	2
2. Regional setting	5
Introduction	5
Importance of overload control	6
Characteristics of commercial vehicles	12
Cost of overloading	18
Regional initiatives to curb overloading	22
Summary	23
3. Review of proposals for overloading control	25
Introduction	25
Determination of economic vehicle load limits	26
Harmonization of vehicle load limits	27
REC proposals for improving overload control	31
Implementation of previous proposals	33

4. Issues affecting an effective overload control	37
Introduction	37
Pre-requisites for effective overload control	37
Implementation barriers and measures for overcoming them	40
5. Emerging good practices within the region	55
Introduction	55
Decriminalization of overloading in Zimbabwe	56
Progressive strategy on overload control in Namibia	58
Privatization of weighbridge operations in the Western Cape	60
Self-regulation of vehicle operations (load control, vehicle maintenance and driver wellness) in South Africa	63
Cross-border overload control system (CBOCS)	65
Summary	68
6. National and regional institutional arrangements for implementation of agreed strategies	71
Introduction	71
Institutional arrangements	71
Proposed new arrangements	75
Summary	78
7. Technical options for dealing with various aspects of overload control	79
Introduction	79
Harmonization of vehicle load limits	80
Enforcement issues	80
Weighbridge infrastructure	87
Management aspects	100
Financing aspects	105
Penalties	110
Human resources and training	111
Public support and cooperation	113
Summary	114
8. Annex: summary of meetings and workshops held in the region from 1985 to 2007	117

FOREWORD

The prevalence of heavy goods vehicle overloading across Sub-Saharan Africa has been a matter of concern for some time. The overloading leads to rapid deterioration of road pavements and imposes a heavy cost on some of the poorest countries in the world. The countries are forced to spend ever increasing amounts on road rehabilitation. Consequently, unless the problem is tackled effectively, there will be no sustainable improvement in the condition of the road network across much of the region.

Numerous attempts have been made to tackle the problem of vehicle overloading, with varying degrees of success. This paper provides a succinct synthesis of the experiences emerging from different countries and draws lessons on how the challenge can be tackled. This synthesis was prompted by the limited success at regional level in the implementation of the regional proposals drawn up by COMESA, EAC and SADC on vehicle overload control and the recent upsurge of activity in a number of countries where substantial investments are being made, or are planned, for the procurement of weighbridge infrastructure. Unless these efforts are properly informed by prior experience, they may fail to address the problem effectively both at national and regional levels.

The paper presents several important findings and recommendations. It is clear that traditional approaches to overload control have generally not worked and indications are that they are unlikely to work in future. It is therefore important to rethink the approaches used. This should not be too difficult as there are a few innovative and successful efforts that can be used to guide new approaches. Furthermore, establishing the right institutional arrangements at both the national and regional levels is key. Vehicle overload control is necessarily a multi-stakeholder effort and the structures have to reflect its multiple dimensions. Otherwise sectoral attempts will lead to partial results that would be difficult to sustain in the long term. Consequently, harmonization and coordination are critical attributes of any sustainable vehicle overload control program. These are only a few of the pertinent issues covered here. Other recommendations include training and capacity building, as well as cooperation between countries. This paper is

therefore one of the most comprehensive assessments of the vehicle overload control efforts in Sub-Saharan Africa and should be a valuable resource for both policy makers and practitioners.

The document is based on a survey of Regional Economic Communities (COMESA, EAC, SADC), international bodies (UNECA, USAID, World Bank), private sector associations (FESARTA), and country experts, who are all critical to the success of any overload control initiative in the region. This synthesis has already been used as an input into the drawing of regional guidelines on vehicle overload control. As is usual with such seemingly difficult subjects, implementing the very sound recommendations here will require serious commitment, support and follow-up from the same parties. What is also true is that the problem can be tackled successfully, but this requires the right mix of approaches, players, deterrents and incentives.

A handwritten signature in black ink that reads "Stephen Vincent". The signature is written in a cursive style and is underlined with a single horizontal line.

Stephen Vincent
SSATP Program Manager

ACKNOWLEDGEMENTS

This report was prepared for the Sub-Saharan Africa Transport Policy Program (SSATP) by the following team of consultants:

Michael I. Pinard, InfraAfrica (Pty) Ltd, Gaborone, Botswana (Team Leader)

Paul Nordengen, Council for Scientific and Industrial Research (CSIR), Pretoria, South Africa

Loest van Eden, Africon Limited, Pretoria, South Africa

Ray Sowman, TMT Projects (Pty) Ltd, Durban, South Africa

The consultants gratefully acknowledge the support and guidance for the project provided by the following persons:

- Dr. Charles Kunaka, who was SSATP Regional Coordinator for East and Southern Africa and primary coordinator of the project
- Mr. Amos Marawa of the COMESA Secretariat in Lusaka
- Dr. Ernest Dhliwayo of the United Nations Economic Commission for Africa (UNECA), Southern Africa Office in Lusaka
- Ms. Mapolao Mokoena of the SADC Secretariat in Gaborone, Botswana
- Mr. Gratian Rutaserwa of the East African Community (EAC) in Arusha, Tanzania
- Mr. Barney Curtis of the Federation of Eastern and Southern Africa Road Freight Associations (FESERTA), South Africa
- Ms. Monique S. Desthuis-Francis, who edited and finalized the manuscript for publication

Many stakeholders, from both the public and private sectors, too numerous to mention by name, provided valuable inputs to the project and their contributions are also gratefully acknowledged.

ACRONYMS

AASHTO	American Association of State Highway & Transportation Officials
ASANRA	Association of Southern Africa National Roads Agencies
AU	African Union
BOT	Built Operate and Transfer
CAPEX	Capital expenditure
CBOCS	Cross Border Overload Control System
CBRTA	Cross Border Road Traffic Agency
CEMAC	Central African Economic and Monetary Community
COMESA	Common Market for Eastern and Southern Africa
CPC	Corridor Planning Committee
CSIR	Council for Scientific and Industrial Research
DoT	Department of Transport
EAC	East African Community
ECA	Economic Commission for Africa
ECOWAS	Economic Community of West African States
ESA	Eastern and Southern Africa
ESA	Equivalent Standard Axle
FCWG	Five Country Working Group
FESARTA	Federation of East and Southern African Road Transport Associations
GCM	Gross Combination Mass
GNP	Gross national product
GVM	Gross Vehicle Mass
HGV	Heavy Goods Vehicle
HSWIM	High Speed Weigh-in-Motion
kg	kilogram
km	kilometer
LAP	Load Accreditation Program

LSWIM	Low Speed Weigh-in-Motion
m	meter
MLP	Model Legislative Provisions
MoU	Memorandum of Understanding
NDoT	National Department of Transport
NEPAD	New Partnership for Africa's Development
OC	Overload control
OCMI	Overload Control Management Initiative
OPEX	Operational expenditure
PAWC	Provincial Administration Western Cape
PBS	Performance Based System
PPP	Public Private Partnership
PTA	Preferential Trade Area
REC	Regional Economic Community
RESOC	Regional System of Overload Control
REVOCA	Regional Vehicle Overload Control Association
REVOCA	Regional Vehicle Overloading Control Association
RTMS	Road Transport Management System
RTQS	Road Transport Quality System
SACU	Southern African Customs Union
SADC	Southern African Development Community
SATCC	Southern Africa Transport and Communications Commission
SCOM	Standing committee
SRO	Sub-regional organization
SSA	Sub-Saharan Africa
TCC	Traffic Control Centre
TMC	Traffic Management Center
VELAC	Vehicle Loading Advisory Committee
VOCWG	Vehicle Overload Control Working Group
vpd	Vehicles per day
WIM	Weigh-in-Motion

KEY MAP

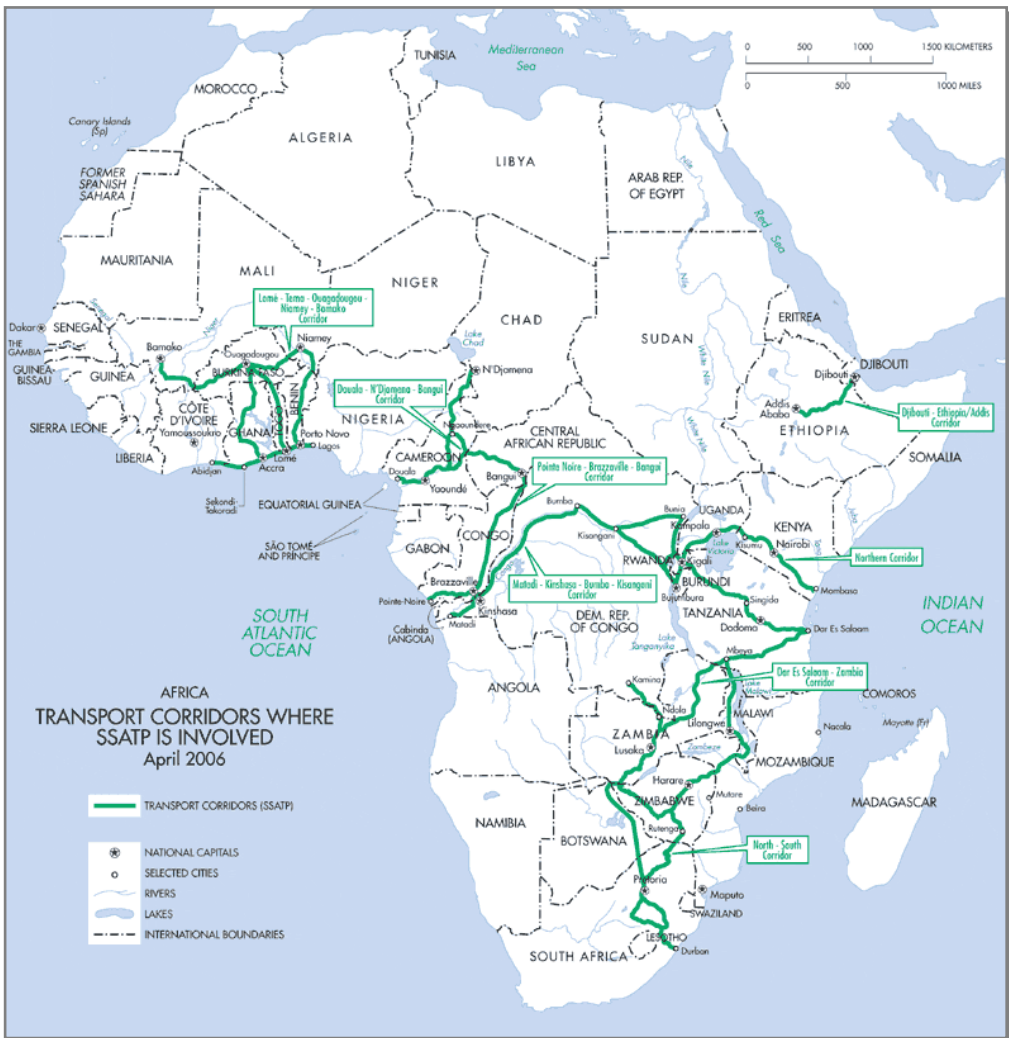

EXECUTIVE SUMMARY

Introduction

Background

1. The Common Market for Eastern and Southern Africa (COMESA), Southern African Development Community (SADC) and the Southern Africa Office of the United Nations Economic Commission for Africa (UNECA) working under the Regional Economic Communities Transport Coordinating Committee established under the Sub-Saharan Africa (SSA) Transport Policy Program (SSATP) have identified vehicle overload control as one of the priority areas to be addressed in their 2006/7 Work Program.
2. One of the projects included in the Work Program was the preparation of a Synthesis Report on Overload Control including the identification of constraints, issues and emerging good practices in overload control in the Eastern and Southern Africa (ESA) region. This project has been prompted by the limited success at regional level in the implementation of the SADC/COMESA proposals on Vehicle Overload Control and the recent upsurge of activity in a number of countries where substantial investments are being made, or are planned, for the procurement of weighbridge infrastructure. Although the project focuses on the Regional Economic Communities (RECs) of the ESA region, it is likely to apply also to other RECs in SSA such as ECOWAS and CEMAC.

Scope

3. The scope of the study has entailed a review of all of the elements that constitute an overload control system including:
 - Legislation & regulations
 - Institutional/organizational
 - Enforcement/operations
 - Infrastructure and equipment
 - Human resources/training
 - Public support/cooperation

Regional setting

Vehicle overloading

4. The issue of vehicle overloading and the urgent need for its effective control in the ESA region have been recognized by various RECs as well as by national governments, for more than two decades. Unfortunately, for a variety of reasons, attempts to control overloading have generally not been effective. The available statistics indicate that incidence of overloading in the ESA region ranges currently from about 10 – 50 percent.
5. Overloading not only significantly accelerates the rate of deterioration of road pavements in the ESA region but, when coupled with inadequate funding for road maintenance, it contributes significantly to poor road conditions and high transport costs, estimated to be typically four to five times higher than those prevailing in developed countries. Based on available information from South Africa, the cost of overloading in that country due to accelerated pavement deterioration as well as increased vehicle operating costs due to poorer road conditions is estimated to be of the order of US \$1.5 billion per annum. When this figure is extrapolated to the ESA road network, the indicative cost of overloading would be in excess of US \$4 billion!
6. The high magnitude of what essentially are avoidable costs due to overloading underscores the importance of dealing effectively with a number of perceived challenges in overload control. In this regard, this paper identifies and addresses various lessons learnt, key issues and challenges, emerging good practice and technical options for dealing with various aspects of overload control in the ESA region as a basis for improving the efficiency of transport operations and facilitating trade along regional transport corridors.

Main lessons learned

Features of the status quo

7. The most significant features of traditional approaches to overload control practiced in many countries in the ESA region and the lessons learnt are as follows:

- Most current systems provide a criminal response to incidences of overloading which results in very low conviction rates due largely to legal technicalities and the inability of the courts to effectively cope with what are considered to be “non-serious” cases compared to more serious crime cases. As a result, there are few incentives to not overload.
- In-house operation of weighbridges involving relatively low paid staff, has generally been conducive to bribery and corruption with the result that unscrupulous operators readily engage in such malpractice.
- The criminal response to overload control offences does not provide any institutional controls or financial links between road authorities and actual road damage.
- There is generally no “price” for overloading and offenders pay little, if any, money to road authorities to compensate for their increased burden of maintenance costs. What they do pay to Government is very low in relation to the cost of the damage done and is not really a deterrent to overloading. Indeed, it pays operators to deliberately overload and pay relatively low fines on “admission of guilt” for so doing.
- Among transport authorities, only the traffic police (and sometimes transport inspectors) have a direct responsibility to control overloading practices. However, their efforts have little deterrent value due to the constraints of the criminal justice system.
- Road authorities, who have a primary responsibility for preserving the road infrastructure, have often a limited role in regulating loading.
- Lack of adequate training of appropriate caliber staff has adversely affected the quality of service provided and the effectiveness of the enforcement process.
- The current systems often fail to achieve the primary goal of preserving the road infrastructure. Instead, they are characterized by inefficiencies, inequities and laxity in the enforcement process.

Key issues and challenges

8. Typical issues and challenges faced by authorities in the ESA region in undertaking effective overload control, and measures proposed for dealing with them are summarized below.

<i>Issue/Challenge</i>	<i>Solution</i>
Lack of an appropriate enabling framework for overload control	Where absent, establish an appropriate enabling framework for overload control via a participatory approach involving both public and private sector stakeholders.
Lack of policy on, or appreciation of, the importance of overload control at national level	Where absent, national public and private sector stakeholders led by the national roads agency to develop an appropriate policy on overload control for inclusion in the country's transport policy.
Lack of harmonized regulations	RECs to harmonize OC regulations including axle load and vehicle/combination mass limits. Countries to amend their regulations so as to ensure compliance.
Lack of regional coordination on overload control	Stronger coordination and dissemination of REC-harmonized policies at regional, sub-regional and national levels by SROs and national bodies.
Lack of awareness of REC recommendations on OC, including the SADC MoU on Vehicle Loading and the MLP on Management of Vehicle Loading	SROs and national bodies to engender awareness and disseminate REC harmonized recommendations on OC, including SADC MLP on Vehicle Loading.
Inadequate/outdated legislation	Where necessary, countries to review/update legislation and regulations in line with REC harmonized recommendations, including SADC MLP.
Lack of regional coordinated siting of weighbridges	Regional weighbridge location plan to be agreed by RECs as blue print for deployment of weighbridges along regional corridors.
Inadequate weighbridge infrastructure	Each country to undertake an inventory and audit of its weighbridge stock and to develop a strategy for gradually replacing inadequate weighbridges in accordance with an appropriate strategy.
Inappropriate selection of weighbridge equipment	The development of a guideline dealing in part with the criteria to be used for selecting weighbridge equipment with the aim of developing a coordinated network of standardized weighbridges strategically located over the regional trunk road network.
Variable weighing conditions	Development of a guideline for the standardized weighing of vehicles for enforcement of axle and vehicle/combination mass limits.
Variations in weighing methods	Development of a guideline for the standardized weighing of vehicles as regards tolerances to be allowed on axles and vehicle/combination mass.
Inadequate overload control operations-lack of effective reporting systems.	An appropriate <i>overload control management system</i> should be installed on all primary weighbridges located at least on regional corridors.
Inadequate overload control operations-	All countries must ensure that the hours of operation

<i>Issue/Challenge</i>	<i>Solution</i>
inappropriate opening hours.	of weighbridge units are synchronized with Customs.
Inappropriate institutional structures and inadequate human resources	Weighbridge operations and institutional structures should be given a much higher profile than hitherto in many countries.
Inadequately trained human resources	Training in overload control should be standardized throughout the region and should follow a prescribed syllabus. Outputs of such training should be certified and accredited with an appropriate educational establishment.
Lack of public support and cooperation	Mount an appropriate public awareness campaign involving all stakeholders and including information booklets or flyers and holding of a national stakeholder workshop involving political leaders.
Inadequate funding for overload control	Need to sensitize Ministries of Finance and lobby political support for overload control. Utilize Road Fund monies for adequately addressing the financial requirements for overload control.

Emerging good practices

9. There exists within the ESA region a number of emerging good practices which, in some way or another, have proven to be very efficient and effective over a sustained period of time in some aspect of overload control. These examples, which are worthy of consideration by all countries, include:
- Decriminalization of overloading by handling them administratively and imposing a requirement on the overloader to pay an overloading fee (e.g. as in Zimbabwe, Tanzania, Malawi).
 - The adoption of progressive legislation and regulations on overload control in keeping with the SADC MLP (e.g. as practiced by Namibia).
 - Outsourcing weighbridge operations to the private sector on a management contract basis, i.e. embarking on a commercialized public/private sector approach to overload control (e.g. as practiced in various provinces in South Africa).
 - Operation of a self-regulatory system which places the onus for overload control on transport operators and freight forwarders to complement law enforcement efforts (e.g. as practiced by the timber and sugar industries in South Africa).

- Adoption of a cross-border overload control system involving the facilitative role of Customs as a link in the chain of enforcement of overload control (e.g. as piloted at the Botswana/South Africa border at Martin's Drift/Groblers Bridge).
10. It is noteworthy that countries that have embarked on reforms in their approaches to overload control in line with the REC recommendations (e.g. Namibia, Tanzania, Malawi, Zambia) have all reported significant reductions in the incidence of overloading. It is also noteworthy that a number of other countries are embarking on the revision of their legislation and regulations dealing with overload control (e.g. Botswana, Mozambique, Uganda, Kenya) in line with the REC recommendations. However, lack of harmonization of many aspects of overload control between RECs, such as SADC and COMESA, results in differences in load limits and regulations that have an adverse effect on the efficiency of transport operations in the ESA region.

Main conclusions and recommendations

Traditional approaches to overload control

11. Traditional approaches to overload control have generally not worked and indications are that they are unlikely to work in future. Past experience has also shown that exclusive reliance on legal load limits and their enforcement may not be enough to ensure effective control. New approaches are required, similar in concept to the Road Management Initiative (RMI), in which various elements of sustainability (political, social, institutional, technical, economic, financial and environmental) should be addressed. Moreover, overload control should become an integral part of road management and the focus needs to be shifted from a *government enterprise* lacking in incentives to *partnerships* with the private sector.

RECOMMENDATION 1

12. Overload control should be viewed more holistically as *overload control management* and should be pursued in the context of an "Overload Control Management Initiative" (OCMI) in which there is greater cooperation and partnership rather than confrontation between public agencies and transporters.

REC proposals for overload control

13. The recommendations contained in the following REC documents provide a framework for a new approach to vehicle loading management which consolidates reform efforts carried out in recent years.
 - SADC – Memorandum of Understanding on Vehicle Loading, March 1999
 - SADC – Model Legislative Provisions on Management of Vehicle Loading, March 1999
 - SADC – Model Agency Contract: Facilitation and Operation of Weighing Stations
 - COMESA – Workshop on Axle Load Limits and Overload Control, Nairobi, Kenya, September, 1999
 - COMESA – Workshop on Axle Load limits, Lilongwe, Malawi. August 2000
14. The above documents take account of international good practice on various aspects of overload control and include a number of trend-setting initiatives that represent a fundamental shift in approach to this activity and, in so doing, respond to the most glaring shortcomings of traditional approaches to overload control. Unfortunately, there is lack of awareness of the existence of the above documents in many countries.

RECOMMENDATION 2

15. The REC recommendations on overload control should serve as a point of departure for application in all RECs. A concerted effort should be made by all stakeholder organizations to raise awareness of the existence of the REC documents on overload control.

Figure 1. Institutional arrangements for overload control

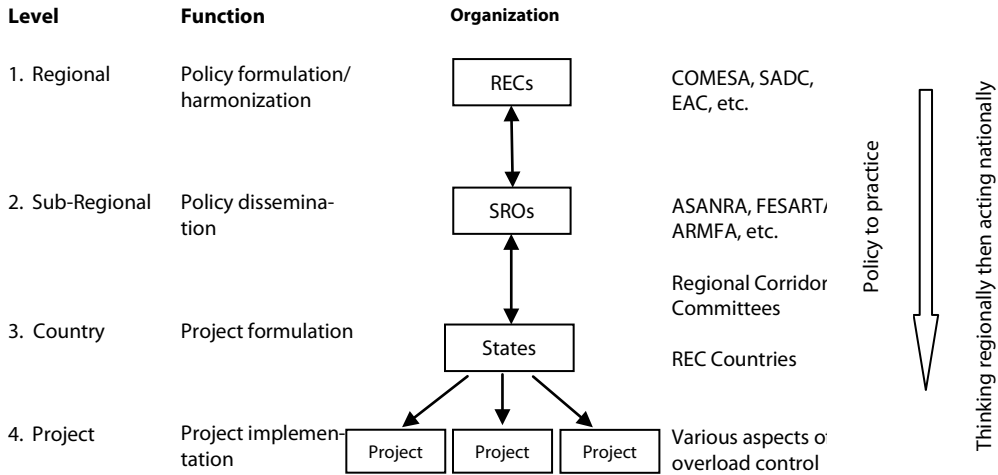

Institutional arrangements

16. Although the REC proposals on overload control provide a regional vision for national improvement of overload control activities, lack of appropriate institutional arrangements to “drive” the process effectively has resulted in uncoordinated approaches at regional level. Moreover, agreements reached several years ago on how best to deal with implementation of these recommendations have lost momentum and, as a result, very little progress has been made in improving overload control in many countries.

RECOMMENDATION 3

17. Establish a clearly demarcated framework with defined roles, functions and responsibilities of the stakeholder organizations involved in overload control along the lines indicated in Figure 1.

Harmonization and coordination

18. One of the seemingly most intractable issues facing the ESA region has been difficulty in achieving an effective, harmonized and coordinated system of overload control management along regional transport corridors and at adjacent borders. This applies to both vehicle load limits and a number of regulations as well as to joint planning and operation of weighbridge infrastructure.

RECOMMENDATION 4

19. Effective overload control to be dealt with as a regional issue with a commonly agreed regional strategy and corresponding Action Plan to be implemented by SROs and national bodies rather than as a national issue that is implemented at national level in isolation of the broader inter-regional nature of transport movements.
20. RECs in collaboration with SROs and member states to promote the regional effectiveness of overload control and oversee the implementation of an integrated Regional System for Overload Control (RESOC) including:
 - Harmonization of measures, procedures and regulations regarding axle load and vehicle mass control
 - Standardization of equipment
 - Coordinated network of standardized weighbridges strategically and equitably spread over the region's main corridors.

Human resources and training

21. The management, operation and maintenance of modern weighbridge scales have increased in complexity in recent years and require a collective range of skills of a managerial, supervisory, technical, legal and mechanical nature.

This requires a cadre of well-educated and properly trained staff who are adequately remunerated. Currently, there is a severe shortage of such personnel.

RECOMMENDATION 5

22. Solicit donor support for the establishment of a regional training centre on overload control employing a harmonized syllabus and catering for the needs of all RECs.

Public awareness and support

23. Despite their expressed intentions to the contrary, there is still lack of political will and commitment by national governments to the issue of overload control. Also, transporters, truck drivers and the general public are often unaware of the full cost implication of overloading and its adverse effect on both the industry and the national economy.

RECOMMENDATION 6

24. (1) Undertake measures to sensitize national governments to the price that their countries are paying for ineffective overload control, including the production of a simple, well-illustrated, appropriately-entitled leaflet on the adverse impact of overloading on the economy.
(2) Make effective overload control a conditionality for any financial assistance for new road projects.

Sustainability of overload control

Dimensions of sustainability

25. Experience in the ESA region has shown that for any project to be sustainable in the long run, it should satisfy simultaneously what has been termed “the seven dimensions of sustainability”. This requirement is no different with overload control, for which the various dimensions are illustrated in Figure 2 which should all be satisfied if long-term sustainability is to be attained.

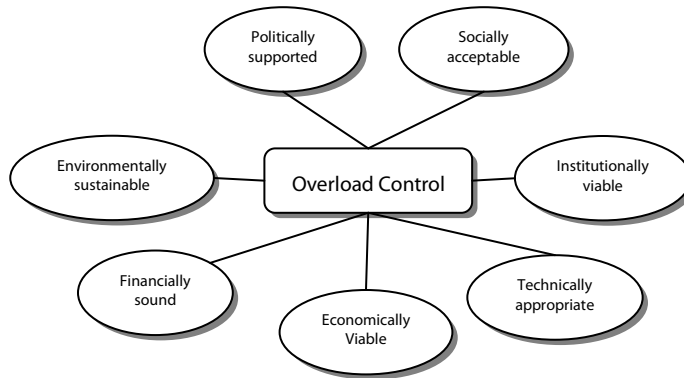
Figure 2 Framework for a sustainable overload control system**WAY FORWARD**

26. The following documentation has been prepared under separate cover as a component of the project for use by member states of all RECs and in order to facilitate the efficiency and effectiveness of their overload control programs:

Case studies on emerging good practices

- Progressive Strategy for Overload Control (as in Namibia)
- Process-related Axle Load Control Program (as in Zambia)
- Decriminalization of Overload Offences (as in Zimbabwe)
- Privatization of Weighbridge Operations (as in the Western Cape, S. Africa)
- Self Regulation of Overload control (as in the timber industry in S. Africa)
- Cross-Border Overload Control System (as at the Botswana/South Africa border)

Guidelines on the following aspects of overload control

- Selection, procurement, installation and operation of weighbridges
- Training of weighbridge personnel

- Financing mechanisms, private sector participation and concessioning of weighbridges
 - Weighbridge data collection, analysis and presentation of results
 - Cross-border overload control
27. Finally, there is a critical need to hold a regional workshop to disseminate the findings of the Synthesis Report and at which all key stakeholders from both the public and private sectors can participate in order to:
- (a) Provide inputs to the various draft guidelines as a basis for their finalization; and
 - (b) Collectively agree the way forward with an agreed implementation strategy on the proposed OCMI at both regional and national levels.

1. INTRODUCTION

PROJECT BACKGROUND

General

1.1 The Common Market for Eastern and Southern Africa (COMESA), Southern African Development Community (SADC) and the Southern Africa Office of the United Nations Economic Commission for Africa (UNECA) working under the Regional Economic Communities Transport Coordinating Committee established under the Sub-Saharan Africa Transport Policy Program (SSATP) have identified vehicle overload control as one of the priority areas to be addressed in their 2006/7 Work Program. In this regard, a project has been proposed to prepare a synthesis report on constraints, issues and prevailing good practices in overload control in the SADC/COMESA regions.

1.2 The project has been prompted by the limited success at regional level in the implementation of the SADC/COMESA proposals on Vehicle Overload Control and the recent surge of activity in a number of countries where substantial investments are being made, or are planned, for the procurement of weighbridge infrastructure.

1.3 While there are several instances of successful vehicle overload control programs in some countries, there also remain problems and constraints in others. Therefore, it is important to identify the bottlenecks and adopt appropriate measures that can address the problems especially at regional level. Despite the existence of what could be examples of good practice, information has not been adequately shared. As a result, costly practices are being pursued in some countries.

1.4 The challenges that arise from the absence of a harmonized framework for overload control management are most apparent along regional transport corridors. The challenges manifest themselves at two levels, firstly, a lack of regional harmonization of axle load limits which makes management difficult, and second-

ly, a lack of faith in the systems used in different countries, such that vehicles sometimes weighed frequently, including at weighbridges a few kilometers apart but on different sides of a common border. Differences in the infrastructure used contribute to varying perceptions of the integrity of the control systems in the different countries crossed by the regional transport corridors, such that each country has to weigh vehicles again as soon as they enter its territory.

1.5 The above issues underscore the importance of a synthesis report as a key input to the transport and trade facilitation initiatives in Eastern and Southern Africa. This approach is likely to increase the chances of regional agreements being reached and implemented at both national and transit transport corridor levels.

GOAL AND OBJECTIVE OF THE PROJECT

1.6 Against the above background, the main goal of the project is to contribute to the general efforts to better facilitate trade along regional transport corridors. The overall objective is to accelerate the implementation of the overload control program based on a thorough appreciation of the underlying issues involved and knowledge of prevailing good practices in the region.

Scope of project

1.7 In pursuit of the above aim and objective of the project, the following activities constitute the scope of work:

- a) Preparation of a Synthesis Report on effective overload control practices
- b) Selection and documentation of good practices as an integral part of the synthesis report
- c) Preparation of draft guidelines on overload control practices, facilities and infrastructure
- d) Presentation of synthesis report and guidelines at a regional workshop and preparation of a final report incorporating the comments and recommendations of the workshop.

Outputs of project

1.8 Following from this scope of work, the outputs of the project are:

- a) A Synthesis Report (this report) which identifies and addresses various key issues and concepts pertaining to overload control in Eastern and Southern Africa.
- b) A harmonized regional implementation strategy on various aspects of overload control developed by stakeholders and in line with regional instruments.
- c) Draft regional guidelines and specifications on various aspects of overload control, designed to facilitate the implementation of fundamental elements of the existing regional instruments, and
- d) Proposals on institutional arrangements for sustainable implementation of the guidelines and specifications for the fundamental elements.

Structure of the document

1.9 The paper is structured as follows:

Section 1 (this section): provides the background to the project as well as its aims, objectives and outputs and the structure of the report.

Section 2: Places the issue of overload control in a regional context and highlights the importance and cost of overloading.

Section 3: Reviews previous proposals on overload control in the region including the outputs of key meetings and workshops.

Section 4: Discusses issues hampering the achievement of effective overload control and proposes measures for overcoming them.

Section 5: Provides examples of emerging good practice in overload control in the region.

Section 6: Reviews regional and national arrangements for implementation of agreed strategies in overload control.

Section 7: Provides technical options on a wide range of aspects of overload control including requirements for achieving sustainability.

Annex: Summarizes the outcome of the various meetings and workshops held in the ESA region dating back to the mid-1980s.

2. REGIONAL SETTING

INTRODUCTION

2.1 Road transport plays a fundamental role in the social and economic development of many developing countries. In Eastern and Southern Africa and, indeed, in all of Africa, it provides the dominant mode of freight and passenger transport and carries between eighty and ninety percent of the continent's total trade in goods and services. Thus, in order to attain acceptable levels of road transport efficiency, the management and maintenance of road infrastructure form an important part of development programs in all countries. In this regard, the control of overloading is of paramount importance as it affects the rate of deterioration and maintenance costs of road pavements.

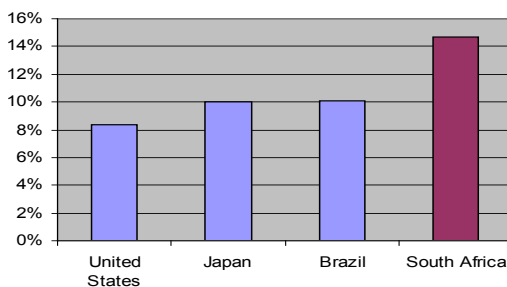

Figure 2.1 Cost of logistics as a percentage of GDP (Source: African Union 2004)

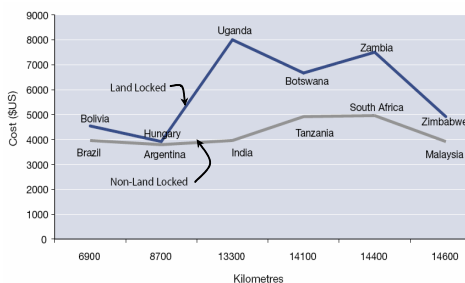

Figure 2.2 Cost of shipments to the US from landlocked and non-landlocked countries (Source: AU 2004)

2.2 Unfortunately, overloading of vehicles in Africa has been an on-going and costly problem for years. When coupled with lack of adequate maintenance, it has resulted in the accelerated deterioration of the region's roads causing the loss of precious infrastructure worth millions of dollars; this has had an adverse impact on the economies of all African countries. For example, transport costs for Eastern and Southern Africa are estimated to be four to five times higher than that of developed countries and for some landlocked countries as high as 30–40 percent of the price of goods. Such high costs not only suppress international trade but also

impact adversely on the economic competitiveness of Africa. This is exemplified by the high costs of Africa's logistics relative to international standards.

IMPORTANCE OF OVERLOAD CONTROL

2.3 In order to fully appreciate the importance of effective overload control, it is necessary to firstly be fully aware of why it is so important to control axle loads and to understand the impact and cost implications of overloading on pavements, bridges and the transport industry and the types of commercial vehicles using the road network. These issues are discussed in this section.

Why control axle loads?

2.4 Road infrastructure represents a huge investment for any country. To protect these assets against misuse and damage, all SADC countries have promulgated Road Traffic Acts that stipulate permissible maximum axle and vehicle mass and dimensions. These limits are meant to ensure that roads last for their full design life with normal maintenance expenditures. In addition, control of axle loads to prescribed limits can be justified for the following reasons:

- Ensuring a level playing field between transporters
- Limiting the extent of road maintenance required
- Reducing the amount of fuel levy required
- Improving road safety

2.5 Laws and regulations to control overloading have been in existence in all ESA countries for more than 40 years. However, in some countries changes to these laws and regulations have not kept pace with transport sector developments while, in other countries, although changes have taken place, they have not been adequately enforced.

2.6 The removal of the protection of railways and the liberalization of the economies of many ESA countries saw a gradual but marked shift from rail to road in the 1980s which became more rapid in the 1990s. This resulted in a significant growth in the road transport sector as manifested by an increase in vehicle numbers, sizes and payload capacity with smaller trucks being substituted with today's vehicle combinations. Such developments have served to highlight the importance of each country not only having up-to-date laws and regulations governing the

control of vehicle load limits, but also the critical importance of enforcing them effectively.

Damaging effect of overloading

2.7 Road pavements are designed to carry a range of “standard” (8.2 tons) axles over a period of time. The number of “Equivalent Standard Axles” (ESA) is determined with respect to the type of traffic expected to use the road over its design life. The American Association of State Highway & Transportation Officials (AASHTO) road tests that were carried out in the USA during the years 1959 – 61 established that the life of a given road is approximately proportional to the fourth power of the axle load for the same number of passes. The test resulted in the following well known formula – the Fourth Power Law – which postulates an exponential relationship between axle loads and damaging power.

Figure 2.3 Damaging effect of overloading

$$LEF = (P/W_s)^n$$

where LEF = load equivalence factor

P = axle load

W_s = standard axle (8.2 tonnes)

n = power law exponent

(typically assumed to be 4.2)

Note: further experimental and research work undertaken since the AASHTO road test has indicated that the power law exponent is related to pavement type (granular, cemented...) and mode of distress (rutting, fatigue, sub-grade deformation...) and may vary from less than 1 to more than 18!

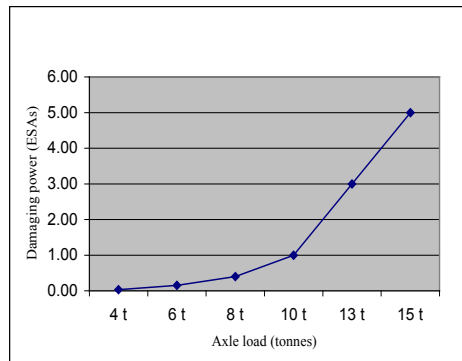

2.8 Recent research has led to a number of modifications and additions to the equivalence factors from the AASHTO road test. In addition to axle load the damaging effect from traffic has been found, amongst others, to depend on the following factors:

- Axle type and spacing (single, tandem, tridem)
- Uneven load distribution on dual tyres
- Wheel type (dual, wide base or single)
- Tyre pressure

2.9 Table 2.1 illustrates the effect of axle load on the design life of a pavement loaded above an assumed legal limit of 10 tons for varying power exponents.

Table 2.1 Effect of Axle Loads on Pavement Life

Design axle load (Tons)	Carried axle load (Tons)	Equivalence factor			Pavement life (years) for Varying power exponent		
		n = 4.0	n = 4.5	n = 5.0	n = 4.0	n = 4.5	n = 5.0
10.0	10.0	1.0	1.0	1.0	20.0	20.0	20.0
10.0	11.0	1.5	1.5	1.6	13.7	12.9	12.4
10.0	12.0	2.1	2.3	2.5	9.7	8.8	8.0
10.0	13.0	2.9	3.3	3.7	7.0	6.1	5.4
10.0	15.0	5.1	6.2	7.6	3.9	3.2	2.6

The above table indicates, for example, that a single axle that is overloaded by just 20 per cent over an assumed legal limit of 10 tons, i.e. loaded to 12 tons, with an assumed power exponent of 4.0, has just over twice the damaging effect (equivalence factor = 2.1) as the legally loaded vehicle. Moreover, if the pavement were to be continually subjected to such overloading in service, its life would be reduced from 20 years to just less than 10 years! It is noteworthy that the effect of the Fourth Power Law on weak pavements can be catastrophic, whilst the effect does not apply significantly to over designed pavements.

2.10 The effect of the exponential relationship is that:

- Most road wear is caused by vehicles with more heavily laden axles (Fig. 2.4)
- A disproportionate share of road wear is caused by overloaded vehicles

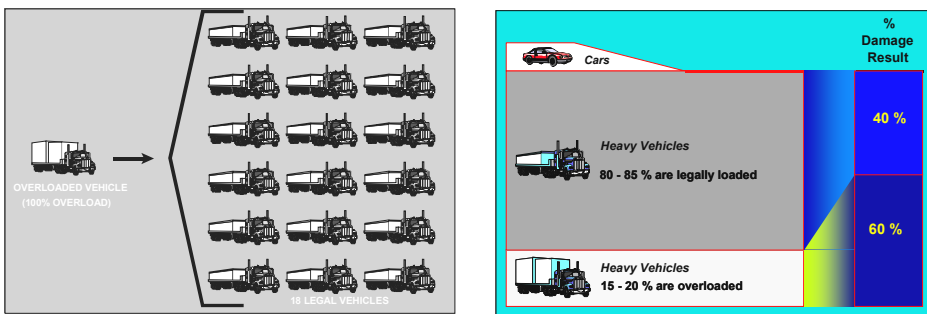

Figure 2.4 Contribution to pavement damage by vehicle category (Ref: The damaging effects of overloaded heavy vehicles on roads. Dept. of Transport, Pretoria, South Africa, April 1997)

As the size of a load approaches the design strength of a pavement or bridge, the effects of the load will be more significant. In these cases, a small number of passages of the load can cause significant structural damage. In an extreme case, a single passage of a grossly overloaded vehicle could cause catastrophic failure.

Impact of overloading on pavements

2.11 As illustrated in Figure 2.3, the impact of overloading on a pavement is to accelerate its deterioration and to cause the pavement to reach its terminal level, usually as a result of unacceptably high levels of rutting or roughness, much sooner than had there been no overloading. As a result, it becomes necessary for rehabilitation to be carried out well before the design life of the pavement has been achieved. This entails expenditure sooner than necessary and the construction of more substantial pavements. Both factors result in increased costs to the roads agency. When this adverse impact is extrapolated to a large proportion of a country's road network, roads agency costs are unnecessarily high.

Figure 2.5 Impact of overloading on pavement performance

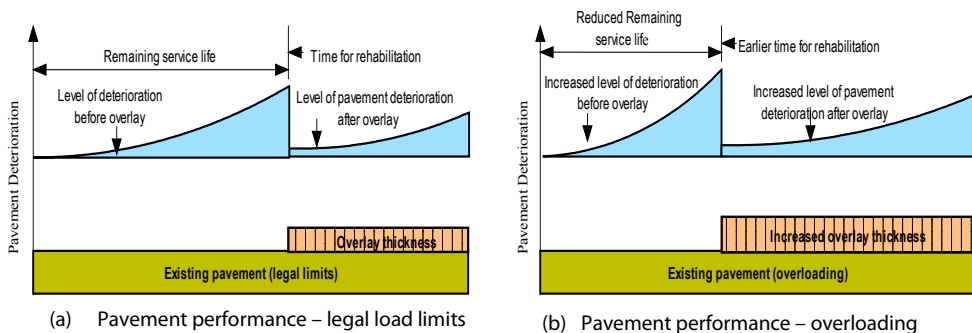

2.12 Rigid 2-axled vehicles constitute a relatively high proportion of overloaded vehicles in the ESA region. This vehicle type is particularly pavement “unfriendly” with a “damage factor” (No. of ESAs/100 tons) that is much higher than multi-axle vehicles - typically of the order of 75 percent to 100 percent!

Impact of overloading on Bridges

2.13 The effects of load on bridges is thought to be more linear than is the case on pavements, with the life of a bridge and the maintenance requirements depen-

dent on the number of passages and the size of the load. While road effects are related to axle mass, bridge effects can be related to either axle mass or the total vehicle mass, depending on the relationship between the axle spacing and the length of the bridge span. Hence, overloaded vehicles are a major contributor to



Overloading causes accelerated pavement deterioration and the need for rehabilitation sooner than normally necessary.

bridge deck deterioration. The extent of deterioration depends on the design load- ing adopted for the bridge. The impact of overloaded axles on short span bridges (< 20 m) relates primarily to tandem and tridem axles. Vehicles that significantly exceed the legal maximum vehicle mass limit raise the prospect of bridge failures, particularly those with short spans and/or low design standards.

2.14 The type of damage which occurs due to overloading is of the following forms:

- **Timber decks:** local failure of timber deck planks, either longitudinally or transversely and loosening of attachment of timber deck planks to supporting members. On timber girder bridges splitting has also been reported as a result of gross overloading.
- **Concrete decks:** cracking of concrete decks, sometimes leading to extensive crack patterns and the formation of block cracking, which in turn can lead to spalling of concrete from either the deck surface or soffit. Composite action between the concrete deck and its members can also be compromised.

Impact of overloading on road safety

2.15 As the degree of overloading increases, major safety issues are raised in addition to non-recovery from the road user of damage to the infrastructure. These issues include:

- Increased severity of accidents when overloaded vehicles are involved
- Reduced grade climbing capability and acceleration
- Greater loss of lateral stability especially when cornering
- Increased braking distance required for overloaded vehicles
- Increased vehicle emissions, noise and ground-borne vibrations

2.16 The severity of road accidents in Africa is extremely high – estimated to be some 30 to 50 times higher than the United Kingdom or the USA. Many of these accidents are caused by overloaded commercial vehicles. The cost of overloading is estimated to consume some 1 to 2 per cent of GNP in Africa [TRL: Towards Safer Roads for Developing Countries, 1991].



Road safety in Africa is adversely affected by overloaded vehicles

Impact of overloading on the transport industry

2.17 Overloading places transporters who abide by the regulations at a disadvantage as they are not able to compete with those transporters that overload. This has an adverse, knock-on effect on the industry as some transporters then resort to overloading in order to be able to compete with those who overload. The net effect is that a transporter's survival in a harshly competitive market is often related to how successful he is at getting away with overloading! Not surprisingly, overloading has become big business as in most cases the fines imposed by magistrates in a

court of law remain unrealistically low compared with the higher profit made by the operator in transporting a heavier load.

CHARACTERISTICS OF COMMERCIAL VEHICLES

Vehicle types

2.18 There is a very wide variety of commercial vehicle types used in the transportation of goods in the ESA region. Figure 2.6 shows a selection of the more common types of commercial vehicles found in the region.

2.19 In addition to the above vehicle configurations, the 32 ton quadrem axle unit, which is not included in either the COMESA or SADC regulations, is legislated in Kenya. Since Kenya is the main country on the Northern Corridor and has the port of Mombasa through which imports and exports for the EAC countries of Uganda, Rwanda and Burundi pass (see Key Map), these countries have also accepted the quadrem axle unit. However, as from December 2007, this configuration will become illegal in Kenya.

2.20 Another feature of the Northern Corridor transport operations is the use of vehicles fitted with lift axles for which there is currently a move afoot in Kenya to ban such axles. However, it is noteworthy that:

- Lifting axles are common in the developed world and make good economic sense for the reduction of tyre wear and less road damage through less dynamic forces, scuffing etc. when vehicles are travelling empty.
- Some transporters operate their vehicles under full load, with an axle lifted. This increases the load on the remaining axle/s and causes a major increase in road damage.

Figure 2.6 Examples of heavy vehicles found in Eastern and Southern Africa

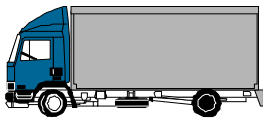

2-axle rigid vehicle

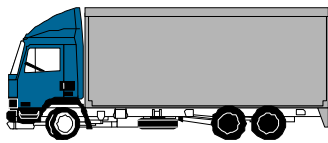

3-axle rigid vehicle

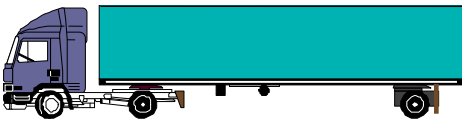

6-axle articulated vehicle

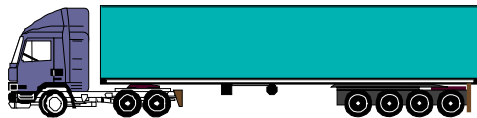

7-axle articulated vehicle

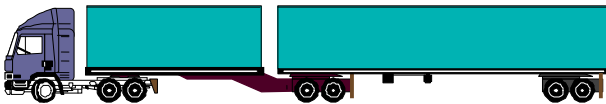

7-axle truck-tractor



Typical quadrem axle unit allowed to operated on the Northern Corridor

Problems caused by quadrem axle units are as follows:

- The damage to the road base is considerably more than for a 24-ton tridem axle unit (the universally accepted axle unit)
- Increased horizontal shear forces at the pavement-tyre interface causing “scuffing” of the road surface during turning manoeuvres, particularly in the vicinity of intersections and roundabouts where tight low-speed turning manoeuvres are executed.
- This axle unit goes against the objective of harmonization of load limits in the region.

2.21 The consultants are of the view that lift axles should not be banned but, rather, that law enforcement should be vigilant enough to stop the lifting of axles when vehicles are under load – a practice that should be supported by the introduction of self-regulation and accreditation as recommended by COMESA.

Total weight/axle load/wheel load/characteristics

2.22 By way of illustration, Figure 2.7 and Table 2.2 show the key data related to the dimensions, mass and load of a commercial vehicle, in this case a rigid, 3-axle vehicle, which is one of the most common commercial vehicle types found in Eastern and Southern Africa.

2.23 The total mass of the unladen or laden vehicle is distributed between the front and rear axles into different axle loads. Each axle load is distributed between the wheels of the axle in question and make up a set of wheels. The wheel loads are transferred to the road surface as a contact pressure between the tyre and the road.

The contact pressure is distributed over the contact area, the so called footprint of the tyre.

Figure 2.7 Example of load distribution on a typical heavy vehicle

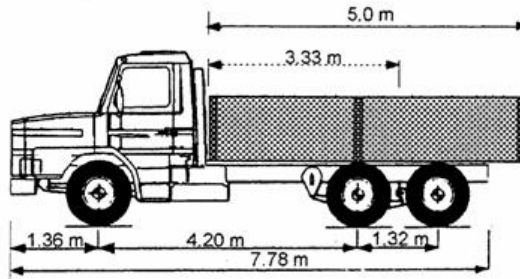

Table 2.2 Example of load distribution on typical heavy vehicle

	<i>Axle</i>	<i>Total load (tons)</i>	<i>Axle load (tons)</i>	<i>Wheel load (tons)</i>
Total mass of unladen vehicle (tons)	n.a*	9.6		
Unladen mass distribution (dual wheels on tandem axles, i.e. 8 wheels) (tons)	Front	n.a	4.4	2.2
	Rear		5.2	0.65
Payload	n.a	15.8	n.a	
Payload distribution	Front	n.a	3.1	1.55
	Rear		12.7	1.59
Total for laden vehicle	Front	25.4	7.5	3.75
	Rear		17.9	2.24

* n.a: not applicable

2.24 The magnitude and distribution of the contact pressure depend on the wheel load and the inflation pressure of the tyre. Figure 2.8 shows how the footprint of a tyre varies with wheel load when the inflation pressure is kept constant. Tyre manufacturers recommend that the inflation pressures be adjusted according to the wheel loads. This will maintain a constant contact area, while at the same time resulting in an increase in the tyre/road contact pressure with increasing wheel load.

Figure 2.8 Tyre footprints for constant inflation pressure and varying wheel load

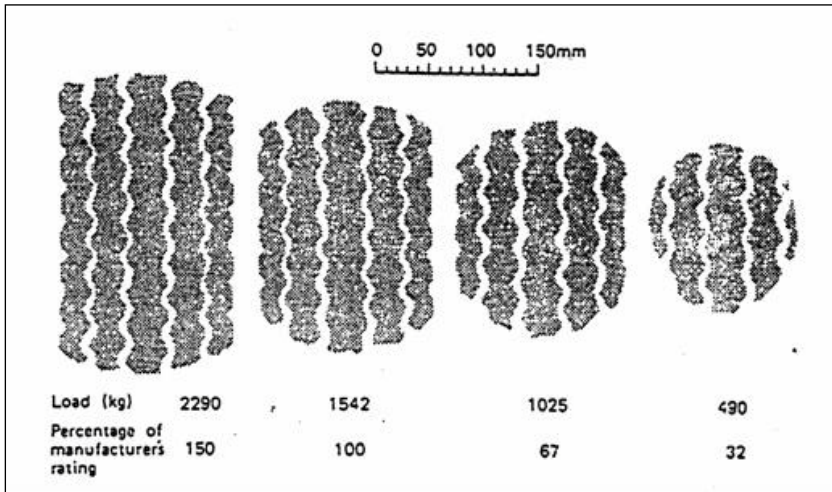

Tyre pressures

2.25 Conventional estimation of traffic for pavement design purposes is usually based only on axle loads. However, tyre pressure is also an important parameter that can influence pavement performance, particularly those constructed with natural gravel, unbound bases. Technical developments in the manufacture of tyres have also made it possible to apply higher tyre inflation pressure than before. As a result, tyre pressures have risen steadily over the years and are now considerably higher (of the order of 800 to 1 000 kPa) than those used in the AASHTO Road Test (550 kPa) which provides the basis for many empirical pavement design methods. It is noteworthy that in the European Union, tyre pressures of 800 kPa are legislated. However, in practice, enforcement of this regulation can be problematic in the ESA region. Nonetheless, tyre pressure should also be taken into account in designing road pavements.

As illustrated in Figure 2.9, the effect of high tyre pressures is to generate high shear stresses in the upper layers of pavements. This is not normally a problem where pavements have been well designed and constructed. However, in certain situations, e.g. steep grades or in poorly drained areas where moisture sensitive, low-strength materials are used, it can be problematic and can result in the cracking of surface layers, rutting from plastic deformation of the base layer, shoving (shear failure) of the base and breakdown of weak aggregates.

Wide single tyres (“super singles”)

2.27 There are many different types of tyres, e.g. with radial or bias ply, normal (250 – 300 mm tread width) or wide base (more than 400 mm tread width). Due to better stability and economy, there has been a trend towards an increase in the use of low profile radial tyres and replacing dual wheels with wide base single wheels (“super singles”), particularly on tridem axle units on trailers. The use of wide single tyres can result in a reduction in total tare weight with a corresponding increase in payload, a lower rolling resistance and less tyre wear. These factors can in turn produce significant cost savings to transporters.

2.28 Research at the Australian Road Research Board (ARRB) (Articulated Vehicle Lateral Stability and Wide Single Tyres, Mai et al, 1985) has shown that wide single tyres significantly improve the rollover stability of heavy commercial vehicles by lowering the centre of gravity and by widening the wheelbase. Other research at ARRB also showed that wide single-tyred axle units cause greater pavement damage, of the order of 25 percent, than dual-tyred axle units with the same loads.

2.29 The legislation in many ESA countries does not deal specifically with the use of wide single tyres. Thus, in the absence of any legislation banning this type of tyre, their use is generally allowed but with the same load limits as for normal single tyres.

Air versus steel suspension

2.30 Vehicles may be fitted with either steel springs or air suspension with the former being generally found on most commercial vehicles in the ESA region. In contrast, air suspensions are more commonly used in Europe and Australia where legislation provides preferential weight limits for these “road friendly” air or equivalent suspensions due to the reduced dynamic loads on pavements. Knowledge of the scientific and economic benefits of these suspensions was very limited until comprehensive experiments were carried out through the OECD Program of Research on Road Transport and Intermodal Linkages.

2.31 In view of the apparent benefits of air over steel spring suspensions a lobby by some transporters, similar to Europe and Australia, tried to introduce an axle loading incentive for vehicles with air suspensions. However, like wide single tyres, the legislation in most ESA countries does not deal specifically with this issue

and no additional allowance is granted for air suspensions. Nonetheless, serious consideration should be given to this initiative which, in the long term, does have the potential for achieving greater efficiency in road transport.

Adequacy of regional road standards

2.32 SADC has promulgated two types of road standards, geometric and pavement. The former are very much road standard related, i.e. the higher the road standard, the "better" the geometrics. The latter, the pavement standard or capacity, is related to the cumulative traffic loading over the design life of the road. Thus, the higher the design traffic loading, the greater the pavement capacity required and the more substantial the pavement requirement. What this means is that for a given loading/overloading scenario, the lower the standard of the pavement, the more quickly it is "consumed" and vice versa. In other words, the higher the standard of the pavement, the less sensitive it is to a variation in axle load.

2.33 Thus, if heavy vehicles were to be confined to the higher capacity pavements as found on the SADC Regional Trunk Road Network (RTRN) or on similar routes in other RECs, the additional damage due to overloading would be within the lower order range of costs derived from the CSIR study referred to in Case Study 3 below. However, this scenario does raise the issue of the need for adopting differential axle load limits on different tiers of the road network – an option with both advantages and disadvantages. On balance, however, the adoption of differential limits would be cumbersome to enforce and would detract from the overriding importance of enforcing agreed limits on all routes as a primary principle and designing the road pavements accordingly. In any case, one would expect most of the intra-regional commercial traffic to use the higher standard RTRN which would offer lower vehicle operation and maintenance costs compared to the relatively lower standard routes.

COST OF OVERLOADING

Cost components

2.34 The marginal cost associated with an overloaded vehicle on a road comprises three main components:

1. The increase in transport cost to other vehicles as a consequence of the overloading. This increase in transport cost reflects the deterioration caused and results in increased costs for operating the vehicle and lower speeds, resulting in higher time costs.
2. Assuming that routine maintenance actions are condition responsive, overloaded vehicles on a road would lead to earlier and more frequent routine maintenance interventions.
3. Overloading will lead to the road authority remedying the damage by way of periodic maintenance actions or reconstruction at an earlier date than would have been the case without the overloaded vehicle.

Incidence of overloading

2.35 Up-to-date, reliable statistics on overloading are generally not readily available. However, from a survey carried out in 2004 (ref. Overloading and Truck Taxation Survey, 2004, prepared by Gicon AS, Norway and InfraAfrica Consultants, Botswana), the incidence of overloading reported by countries in the SADC region was as follows:

Table 2.3 Reported incidence of overloading in the SADC region (2004)

<i>Country</i>	<i>Percent overloading</i>
Angola	?
Botswana	10-25
Lesotho	20-35
Malawi	30-40
Mozambique	50
Namibia	20
South Africa	15-20
Swaziland	20-40
Tanzania	20-30
Zambia	40
Zimbabwe	5-10

2.36 Based on the information contained in various country reports, it appears that the above range of overloading is of a similar order in the COMESA and EAC countries. It is also noteworthy that in those countries that have reformed their overload control strategies in line with the SADC MoU on Vehicle Loading, such

as Namibia and Tanzania, the incidence of overloading reported in these countries in 2006 has been reduced to less than 10 percent.

Case studies on cost impact of overloading

2.37 The following case studies 1 and 2 are extracted from a Preferential Trade Area (PTA) report PTA/TC/TCD/XII/4 dated July 1992 that was presented at the Twelfth Meeting of the Transport Communications Committee, Lusaka, Zambia, 6-9 August 1992. Case Study 3 is from South Africa.

Case Study 1

A section of international highway was reconstructed at a cost of \$230 000 per km. Its design life was 15 years and its capacity 25 million ESA. Traffic studies showed that the average ESA for all vehicles with more than 2 axles was 6.56, and that the average axle load for all axles of vehicles in this class was between 9 and 10 tons. To achieve these figures an average of every single vehicle with more than 2 axles would need to be overloaded. However, in this case, many vehicles were partially loaded or even empty; therefore the degree of overloading on a fraction of the total traffic was extreme.

The pavement suffered catastrophic failure within three years of opening for traffic. In order to sustain its residual design life (i.e. at the end of 12 years), an additional US\$ 214 000 per km is required for strengthening. If it is assumed that other factors (workmanship, materials, supervision) contributed 50 percent to the failure, the uncontrolled loading of HGVs will cost at least US\$107 000 per km.

Case Study 2

On another international highway, a single HGV articulated vehicle consisting of a prime mover with tandem drive, and a triple axle group semi-trailer was weighed, and its axle loads were as follows:

Steering axle:	8.2 tons
Tandem axle unit (drive axle unit):	36.7 tons
Tridem axle unit:	59.5 tons
Total vehicle mass:	104.3 tons
Payload (approx.)	90 tons

Using the conventional form of Liddle's Formula, the ESA on this vehicle was more than 246. Under the PTA 10 ton single load/drive axle, this vehicle was equivalent to more than 40 similar vehicles loaded to the legal limit, and yet its payload was about 3 times what it should have been. If a higher value of the exponent should be used for relatively weak pavements and high axle loads, then the ESA for this vehicle would have been 1,434. In other words, it was equivalent to 239 identical vehicles loaded to the legal limits. While this example may be considered extreme, there is every reason to believe that gross overloading is a common occurrence on every major paved road in the PTA region.

Case Study 3

Analysis of severely overloaded heavy vehicles undertaken by the South African Council for Scientific and Industrial Research (CSIR) in 2003 and 2004 indicates typical road damage costs for heavily overloaded vehicles. For example, a vehicle overloaded by 37.22 tons (travelling from Zambia to South Africa – see photograph below) travelling on a typical relatively high standard national road in South Africa, causes additional damage over and above the legal payload of the order of **\$2,500 – \$3,500 per 1,000 km**. On a less substantial provincial road the additional damage would be of the order of **\$10,000 per 1,000 km** and could even extend to over **\$14,000 per 1,000 km** depending on the design of the pavement. In contrast, the illegal profit made by the operator was estimated at between **\$5,000** and **\$7,000**.

Extrapolation of cost of overloading to ESA region

2.38 Road damage costs in South Africa caused by overloaded heavy vehicles have been estimated at approximately \$170 million per annum plus an amount of \$1 330 million for increased vehicle operating costs due to poorer road conditions. When such typical costs are extrapolated over the ESA region's main paved road network of approximately 90,000 km, where overload control is generally less effective than in South Africa, the estimated cost due to overloading is in excess of \$4 billion per annum.

REGIONAL INITIATIVES TO CURB OVERLOADING

REC initiatives

2.39 The issue of overloading and the urgent need for its more effective control has been a key item for consideration by all RECs in the ESA region for many years. Some of the first recommendations were made by both the Southern Africa Transport and Communications Commission (SATCC) working Groups on Road Infrastructure and Road Traffic and Transport as well as the Preferential Trade Area (PTA) for Eastern and Southern Africa in the mid-1980s. These initiatives have continued ever since with numerous subsequent workshops and meetings, albeit with limited success. The reasons for lack of implementation of many of these previous proposals are as reviewed in the next section.



Overloading – The curse of the
ESA region's roads



2.40 There are also a number of on-going projects including an axle load control component in the current road funding programs under a number of cooperating partners such as the African Development Bank, the World Bank, bi-lateral lending/grants and government funding. Examples of such projects include:

- Northern Corridor rehabilitation covering Kenya, Uganda, Rwanda and Burundi
- Isiolo/Merile segment of the isiolo/Moyale road linking Kenya and Ethiopia
- Arusha/Athi River (Kenya/Tanzania)

- Rehabilitation projects in Tanzania
- Kafue/Chirundu (Zambia)

SUMMARY

2.41 This section has highlighted the critical importance of overload control in Africa in general, and more specifically in Eastern and Southern Africa, which is the focus of the report. The importance of controlling axle loads due to the exponential damaging effect of loads in excess of legal limits has been emphasized and the impact of overloading on road infrastructure, road safety and the transport industry illustrated. The influence of high tyre pressures has also been highlighted as well as recent developments including the use of wide single tyres and air suspensions. The cost of overloading has been quantified from previous case studies and has been shown to be substantial. Finally, an illustrative example has been presented to demonstrate the effect of vehicle overloading on payload and pavement damage.

2.42 This section has emphasized that overloading by some unscrupulous transporters is self-defeating in that such malpractice may increase their profits in the short term but, in the long term, the national economy suffers due to increased transport costs brought about by increased vehicle operating costs (caused by poorer road conditions and borne by transporters but usually passed on to customers) and increased road maintenance and rehabilitation costs (borne by the roads agency and passed on to Government).

2.43 The importance of overload control is well summed up from the proceedings of a COMESA Workshop on Axle Load Limits and Overload Control, Nairobi, Kenya, 1999, as follows.

2.44 In the final analysis, overloading may be described as the curse of ESA's roads. In the interest of the economies of these countries, it must be minimized through appropriate laws and regulations that are effectively enforced. Past approaches have unfortunately not been very effective. New approaches are required involving the closer cooperation of all parties in the transport logistics chain.

3. REVIEW OF PROPOSALS FOR OVERLOADING CONTROL

INTRODUCTION

Background

3.1 There has been a long-standing recognition by a number of regional and sub-regional bodies in Africa that controlling vehicle loads through appropriate mass regulations and effective enforcement is critical to preserve the life of a road pavement and, in so doing, enhance the efficiency of road transport operations. In fact, the issue of overload control has been on the agenda of these bodies for more than two decades dating back to the mid 1980s. During the intervening period, numerous investigations, studies and workshops have been held and numerous reports have been produced both by these organizations themselves and by others on their behalf. Despite these initiatives, effective overload control has remained an elusive goal which continues to receive attention by many stakeholders who strive to improve the status quo. In so doing, there has been an evolution in thinking as regards how best to control vehicle loading.

Objective

3.2 Against the above background, the main objective of this section is to present the mass regulations promulgated by regional bodies for controlling axle loads and maximum vehicle/combination mass in the Eastern and Southern Africa (ESA) region. This information provides a backdrop for summarizing proposals to improve the efficiency and effectiveness of overload control that have emanated from the outputs of the more important regional workshops and meetings that have taken place over the past two decades.

DETERMINATION OF ECONOMIC VEHICLE LOAD LIMITS

The concept of economic axle load limits

3.3 At the core of any system of overload control are the actual regulations that, amongst others, place limits on the permissible maximum axle, axle unit, vehicle and vehicle combination masses for vehicles using a country's road network. In theory, such limits should strike a balance between two important transport planning considerations:

- The benefits to be derived from a reduction in transport costs obtained from the economies of scale and the efficiency of operating larger and heavier vehicles; and
- The costs of road pavement provision and maintenance which are both related to axle loads, and bridge standards which are related to a vehicle's total mass.

Figure 3.1 – The concept of the economic axle load limit

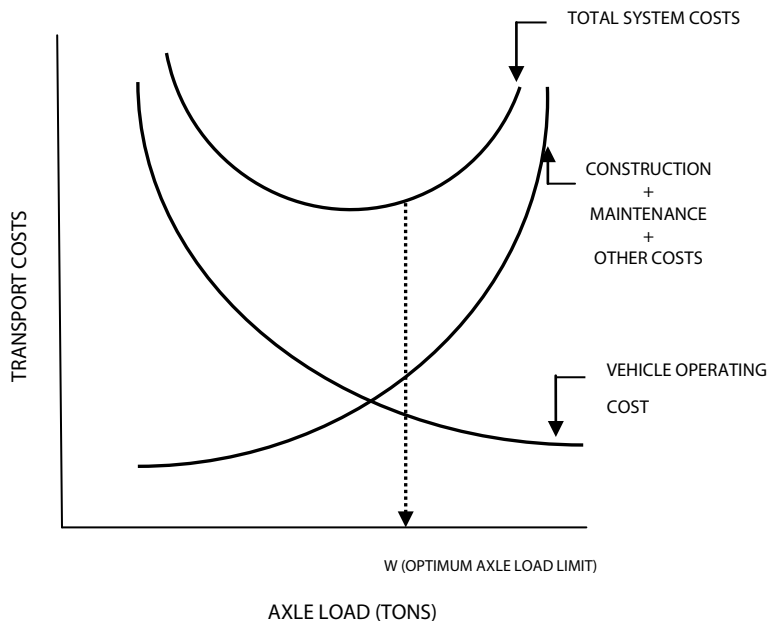

3.4 Thus, balance of the road transport system would not be achieved if either heavier axle loads were to cause more damage to the road infrastructure than benefits accruing from a reduction in freight transport costs or, conversely, if lighter axle loads were to cause more loss of freight transport benefits than savings in infrastructure costs. The concept of the economic axle load can best be illustrated with reference to Figure 3.1, which shows the various interacting elements of the transport system in relation to the derivation of optimum axle load limits.

HARMONIZATION OF VEHICLE LOAD LIMITS

3.5 The vehicle load limits in Eastern and Southern Africa can generally be said to have evolved over the years on no particular basis other than what might be described loosely as “historical trends”. In the late 1980s both COMESA and SADC developed their own protocols to harmonize axle load limits and other aspects of overload control within their respective economic communities. The approaches adopted differ as described below.

COMESA approach

3.6 In the absence of the availability of economic and engineering data that would be required to rationalize the setting of axle load limits, a 1988 PTA *Study on the Harmonization of Road Tolls, Transit Charges, Axle Loads and Vehicle Dimensions* took as its base the following:

- Facilitation of enforcement
- Least modification of existing limits
- Technical considerations

3.7 On the above basis, recommendations were put forward that would involve the least modification of regulations to the maximum number of countries. The recommendations, which are still in force, are as follows:

- | | |
|--|-----------|
| ▪ Steering axle | 8.0 tons |
| ▪ Single/drive axle | 10.0 tons |
| ▪ Tandem drive/load axle | 16.0 tons |
| ▪ Tridem axle | 24.0 tons |
| ▪ Permissible maximum combination mass | 53.0 tons |

SADC approach

3.8 On the basis of an *Axle Load Study for Southern Africa* carried out by SATCC in 1999, optimum axle load and maximum vehicle mass limits (i.e. those limits which minimize the total transport cost on a regional basis for the regional economy) were determined using a techno-economic model – the World Bank’s HDM-III model.

3.9 Based on the outcome of the HDM-III analyses, the regional optimum single axle load limit was determined as 13 tons. However, based on consideration of the axle load Economic Efficiency Frontier, in terms of the benefits versus costs of increasing from the prevailing limits to the optimum limit, the harmonized limits recommended for the region were less than the optimum limits (ref. Figure 3.1 and Table 3.1).

Figure 3.2 Axle load Economic Efficiency Frontier

Table 3.1 NPV of transport costs in relation to increase in axle load limit versus NPV

Increase in axle load limit		Benefit/cost ratio
From	To	
8.2	10.0	10.1
10.0	12.0	3.6
12.0	13.0	1.7

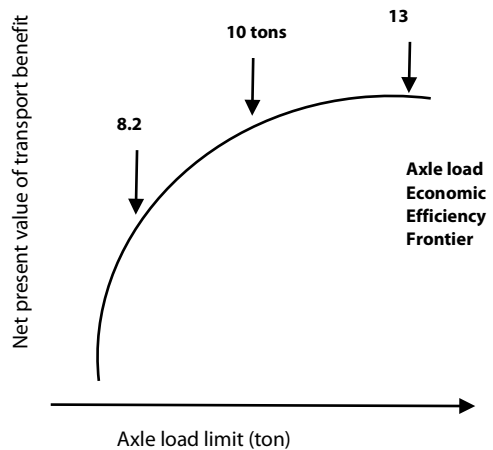

3.10 In addition to axle load economic efficiency considerations, there were a number of other reasons for recommending limits which were less than the optimum limits. These included the large proportion of sub-standard pavements, a significant amount of backlog maintenance and concern over the adequacy of future maintenance funding. In the event, the recommended regional axle load and gross combination mass limits for the SADC region were as follows:

- Steering axle 8 tons

▪ Single/drive axle	10 tons
▪ Tandem drive/load axle	18 tons
▪ Tridem axle	24 tons
▪ Permissible maximum combination mass	56 tons

3.11 As is clear from the above, both the COMESA and SADC recommended limits are the same for steering, single/drive and tridem axles but differ for the tandem drive/load axles and the maximum combination mass. Thus, in theory, *there is an agreed basis at REC level for inter-regional harmonization of axle load and maximum combination mass limits in the COMESA and SADC regions*. However, by the same token, because some of the axle load and the maximum combination mass limits are different, *there is no intra-regional harmonization of limits* - a long-standing problem, amongst others, that continues to adversely affect the efficiency of intra-regional transport.

Comparison with other REC limits

3.12 Table 3.2 shows the comparison of the COMESA and SADC main vehicle load limits with those of other RECs in Eastern and Southern Africa.

Table 3.2 – Comparison of REC vehicle load limits

REC	Axle load limit (tons)				Perm. Max. Comb. Mass (tons)
	Steering axle (2 tyres)	Single axle (4 tyres)	Tandem axle unit (8 tyres)	Tridem axle unit (12 tyres)	
COMESA	8.0	10	16	24	53*
SADC	8.0	10	18	24	56
ECOWAS	8.0	12	21	25	51
CEMAC	8.0	13	21	27	50

* Permissible maximum combination mass still subject to a "bridge formula" study

3.13 As would be apparent from Table 3.2, vehicle load limits within various RECs vary considerably. Although some of the differences in limits may appear to be relatively small, as indicated in Section 2 of this report, the damaging effect on the road pavement can be substantial due to the exponential relationship between axle loads and damaging power.

Prevailing axle load and maximum combination mass limits

3.14 In practice, notwithstanding the recommended SADC and COMESA axle load and maximum combination mass limits, *there is still lack of inter-regional harmonization*. For example, in a number of EAC countries, a 32 ton quad axle configuration is allowed, although as from December 2007 it will become illegal in Kenya. In addition, as illustrated in Table 3.3, there are still many variations in load limits in the COMESA and SADC regions, made worse by some countries belonging to both RECs.

Table 3.3 Variation in vehicle load limits in selected SADC and COMESA countries

Countries by Region	Steering Axle		Non-Steering								Permissible Max. Comb. Mass (tons)
	Single	Tandem	Single		Tandem		Tridem		Quadrem		
	2 tyres	4 Tyres	2 Tyres	4 Tyres	4 Tyres	8 Tyres	6 Tyres	12 Tyres	8 Tyres	16 Tyres	
SADC	8	-	-	10	-	18	24	24	-	-	56
Angola*	6	-	-	8	-	16	-	24	-	-	38
Botswana	7.7	-	8	8.2	15.4	16.4	23.1	24.6	-	-	50.2
DRC*											
Lesotho	7.7	-	8	8.2	15.4	16.4	21	21	-	-	49
Malawi*	8	-	8	10	16	18	24	24	-	-	56
Mozambique	8	-	8	8	16	16	24	24	-	-	38
Namibia*	7.7	-	8	9	16	18	24	24	-	-	56
South Africa	7.7	15.4	8	9	16	18	24	24	-	-	56
Swaziland*	7.7	-	8	8.2	15.4	16.4	21	21	-	-	50.2
Tanzania	8	12	8	10	12	18	15	24	-	-	56
Zambia*	8	-	-	10	-	18	12	24	-	-	56
Zimbabwe*	7.7	-	8	10	16	18	24	24	-	-	56
COMESA	8	-	8	10	16	16	24	24	-	-	53
Burundi	8	-	-	10	-	16	-	24	24	32	N/A
Ethiopia	8	-	-	8	-	16	-	24	-	-	-
Eritrea	6	-	-	8	-	16	-	24	-	-	46
Djibouti	6	-	-	8	-	16	-	24	-	-	46
Kenya	8	-	6	10	12	16	18	24	-	-	53
Sudan	7.7	-	-	10	-	16	-	22	-	-	46
Uganda	8	14	8	10	12	16	18	24	24	32	46
Rwanda	8	-	-	10	-	16	18	24	24	32	N/A

* Denotes country is also a member of COMESA

N/A = Not applicable

 Denotes compliance with recommended limit

Vehicle dimension limits

3.15 Table 3.4 shows the comparison between the COMESA and SADC vehicle dimension limits.

Table 3.4 Comparison of REC vehicle dimension limits

<i>REC</i>	<i>Vehicle combination length (m)</i>	<i>Articulated vehicle length (m)</i>	<i>Rigid vehicle length (m)</i>	<i>Trailer length (m)</i>	<i>Semi-trailer length (m)</i>	<i>Width (m)</i>	<i>Height (m)</i>
COMESA	22	17	12.5	12.5	12.5	2.65	4.6
SADC	22	18.5	12.5	12.5	N/A	2.6	4.6

3.16 As would be apparent from Table 3.4, there are minor variations in vehicle dimension limits between COMESA and SADC. In practice, however, due to lax enforcement of these limits, much longer truck-trailer combinations are often seen on regional roads and have the potential for causing safety problems, especially at roundabouts and intersections (cutting of corners) that have not been designed for such dimensions.

REC PROPOSALS FOR IMPROVING OVERLOAD CONTROL

Documents reviewed

3.17 Since the late 1980s both COMESA and SADC have made strenuous attempts to improve overload control in Eastern and Southern Africa through the holding of various workshops and meetings and the production of various reports. Table 3.5 lists some of the more important documents reviewed by the consultants as a basis for extracting from them some of the important proposals that have been made at regional workshops and subsequently assessing the extent to which these proposals have been implemented.

3.18 The objectives and main recommendations emanating from the above workshops, meetings and reports which are generally shared by all the RECs are detailed in Annex A and may be summarized as follows:

- Government-driven approaches to overload control have generally not worked. The private sector should become more involved in various aspects of overload control operations ranging from outsourced management to full privatization.

Table 3.5 List of documents reviewed

<i>Organization*</i>	<i>Title</i>	<i>Date</i>
SATCC	Control of Overloading in Southern Africa	Nov 1985
SATCC	Overload Control and Weighbridges. Review of Present Situation in the SADCC Region. WP of 7 November 1991	Nov 1991
SATCC	Review of Present Situation and Previous SATCC Proposals. WP of February 1992	Feb 1992
PTA	Institutional Policies and Measures For Regional Axle Load Control	July 1992
SATCC	Axle Load Study for Southern Africa. Final Report	May 1993
SATCC	Axle Load and Gross Vehicle Mass Control. Fee Schedules for Overloading	Nov 1993
SATCC	Five Country Special Working Group on Overload Control. Final Report	Feb 1994
SATCC	Vehicle Overload Control Workshop, February 24-26, 1998, Maputo, Mozambique	Feb 1998
SATCC	Enabling Legal Reform: Control of Vehicle Loading	Mar 1999
SATCC	Inaugural Meeting of Regional Vehicle Overloading Control Association, Gaborone, Botswana	Aug 1999
COMESA	Workshop on Axle Load Limits and Overload Control, Nairobi, Kenya	Sept 1999
COMESA	Workshop on Axle Load limits, Lilongwe, Malawi	Aug 2000
ECA/SRDCA	Draft Action Plan for Implementing the Axle Load Control Program	June 2001
SADC/COMESA	Sub-Saharan Africa: Overloading and Truck Taxation Survey	Aug 2004
USAID/SAGCH	Cross Border Overload Control Project	Aug 2004
ASANRA	Workshop on Vehicle Overload Control, Gaborone, Botswana	Feb 2007

* Indicates regional body under whose auspices the report was produced

- Within the legal framework for overload control, an “infringement” system should be introduced in place of the more traditional “prosecution” system. This system will treat most offences out of court (there can still be legal recourse to the courts by transporters) and the “fees” rather than “fines” will be dealt with by administrative rather than legal procedures.
- Penalties for overloading should be determined on a standardized basis and be based on a progressive overload fee system. All fees should be paid into a dedicated Road Fund (where they exist) and the revenue used for maintenance purposes.
- The adoption of a regional, integrated approach to overload control focusing on vehicles moving on the regional corridors. In this regard, members

states should “think regionally and act nationally” so as to ensure convergence of policies, joint planning and operation of weighbridge infrastructure, harmonization of standards, joint cross-border operations and accession to regional protocols.

- Greater standardization of weighbridge infrastructure; sharing, and thereby reducing, weighbridge installations at border posts of adjacent countries and common training standards at regional level.
- The critical need for formalized training in all aspects of overload control at a regional institution using a common syllabus.
- The emergence of a number of innovative approaches to overload control, including “self-regulation” which should be encouraged for more widespread adoption in the ESA region.
- The establishment of appropriate national and regional institutional structures to “drive” the control process in a more structured and coordinated manner, and
- The development of guidelines to assist all members states in improving the efficiency and effectiveness of their overload control operations.

IMPLEMENTATION OF PREVIOUS PROPOSALS

Assessment of progress

3.19 Table 3.6 assesses the extent to which various key proposals on overload control have been implemented in ESA. This assessment is based partly on the results of a survey carried out for Deutsche Gesellschaft für Technische Zusammenarbeit (GTZ) in 2004 (ref. *Overloading and Truck Taxation Survey* by Gicon AS, Norway and InfraAfrica Consultants (Botswana)) and partly on the information contained in the various reports listed in Table 3.5.

3.20 As indicated in Table 3.5 *there is still lack of intra-regional harmonization on many key aspects of overload control*. Although a certain amount of inter-regional harmonization is taking place within a particular REC, this is often at variance with the harmonization that is taking place within another REC. Thus, in terms of the way forward, the highest priority should be given to intra-regional

harmonization of key aspects of overload control. These key aspects which all have a broad regional aspect to them include:

- Vehicle mass and dimension limits
- Measures, procedures and rules governing overload control including:
 - Weighing methods and tolerances
 - Standardized axle load compliance certificate
 - Transportation of hazardous substances
 - Transit containers
 - Common basis for determining fees
 - Monitoring of compliance and sharing of information at regional level
- Standardization of weighbridge equipment including:
 - Minimum standards
 - Calibration/verification
 - Regional siting of weighbridges at borders and along main corridors
 - Regional training, including a common syllabus

3.21 Once *intra-regional* harmonization of the above aspects of overload control has been achieved, *inter-regional* harmonization can then proceed in the full knowledge that all countries the ESA region will be “thinking regionally and acting nationally” – a pre-requisite for achieving the goal of all RECs as regards improving intra- and inter-regional road transport efficiency as affected by overload control operations.

Impact of implementation of proposals on incidence of overloading

3.22 Up-to-date, reliable data on a historical basis is generally not available in many ESA countries. However, two countries which have recently reformed their approaches to overload control by implementing most of the recommendations of the SADC MLP on vehicle loading have demonstrated the beneficial impact on a reduction in overloading as shown in Table 3.7. This suggests that the potential for reducing overloading is certainly high in those countries where adequate attention is paid to the various elements of an appropriate overload control strategy.

Table 3.6 Implementation of previous proposals

<i>Proposals for Improving Overload Control</i>	<i>Implementation</i>	<i>General Comments</i>
1. Legislation and regulations		
Intra-regional harmonization of vehicle load limits (REC)	low	Lack of COMESA/SADC/EAC harmonization
Intra-regional harmonization of other regs on OC (REC)	low	Lack of COMESA/SADC/EAC harmonization
Inter-regional harmonization of vehicle load limits	medium	All countries gradually harmonizing to REC limits
Inter-regional harmonization of other regs on OC	medium	All countries gradually harmonizing to REC limits
Decriminalization of OC offences	low	Introduced in only a few countries; others considering
Introduction of economically based fees	medium	Introduced in some countries; others considering
2. Infrastructure and equipment		
Regional coordinated citing of weighbridges (REC)	low	Insufficient attention at regional level
Standardized calibration of weighbridges (REC)	low	Inter- and intra-regional variations exist
Standardization of weighbridge equipment	low	Tends to be project specific or donor influenced
Adequacy of number of weighbridge	low	Insufficient numbers of weighbridges
Proper installation of weighbridge equipment	medium	Improving with installation of new weighbridges
Greater cross-border cooperation	low	Successful implementation of a pilot project
3. Enforcement and operations		
Harmonization procedures and rules governing OC (REC)	low	Still lack of COMESA/SADC/EAC harmonization
Standardization of weighing procedures	low	Inter-regional variations. Need for manuals.
Improved monitoring of compliance	low	Improving in few countries. Need for data management.
4. Institutional arrangements		
Introduction of self-regulatory system	Low	Introduced in South Africa; being considered elsewhere
Contracting out weighbridge ops to private sector	Low	Introduced in South Africa; being considered elsewhere
Establishment of national structures to oversee OC	medium	Exists only in some countries
5. Human Resources and Training		
Harmonized training on a regional basis (REC)	low	No progress with implementation
Adequacy/capacity of human resources	low	Trained manpower lacking in many countries
5. Public awareness and cooperation		
Educational campaigns	medium	Sensitization of stakeholders in some countries

Table 3.7 Impact of Reform on overloading

<i>Country</i>	<i>Incidence of Overloading (%)</i>	
	<i>Pre-Reform</i>	<i>Post-Reform</i>
Namibia	28.9	10
Tanzania	40	10

3.24 The section also reviewed previous documentation on overload control emanating from numerous meetings, workshops and reports that have taken place over the past two decades in the ESA region. The outcome of the review has revealed that, in general, there is a common recognition by stakeholders of the shortcomings and inadequacies of current approaches to overload. However, there is still a lack of intra-regional harmonization on many key aspects of overload control and although a certain amount of inter-regional harmonization is taking place within a particular REC, this is often at variance with the harmonization that is taking place within other RECs.

4. ISSUES AFFECTING AN EFFECTIVE OVERLOAD CONTROL

INTRODUCTION

Background

4.1 As would be apparent from Section 3, over a period of more than 20 years, numerous surveys, meetings and workshops have been held and many reports produced on various aspects of overload control in the SADC/COMESA region. The single recurring theme amongst the voluminous amount of documentation produced during the period under review is that implementation of agreed recommendations on overload control has, at best, been moderate. This general lack of success has led to repeated exhortations at meetings and workshops for member states to implement the agreements reached as soon as possible. Invariably, promises made at such gatherings have not materialized in practice. This does beg the question – why has implementation proved to be so elusive?

Objectives

4.2 Against the above background, this section considers the following issues:

- The pre-requisites for effective overload control
- The barriers affecting the implementation of previous proposals on overload control and measures for addressing them

Whilst the various issues are not discussed on a county-specific basis they, nonetheless, provide a benchmark against which countries can aspire in terms of improving their approaches to overload control.

PRE-REQUISITES FOR EFFECTIVE OVERLOAD CONTROL

General

4.3 Certain pre-requisites need to be satisfied if the successful practice of overload control is to be achieved in the SADC/COMESA region. These pre-requisites which are discussed below are:

- The existence of a national enabling framework that is conducive to undertaking overload control within an agreed regional framework
- The existence of a holistic strategy for carrying out overload control at national and regional levels

Enabling framework

4.4 In principle, an enabling framework for overload control should exist in every country. Such a framework would contain, in hierarchical order, a number of interdependent elements as illustrated in Figure 4.1. These elements would guide the manner in which overload control projects are implemented. For example, in the absence of a supporting policy on overload control, there would be little likelihood of obtaining funding for construction of new weighbridges or of improving institutional arrangements for carrying out overload control operations. Thus, it is of paramount importance that at least the higher order elements of the enabling framework are in place, i.e. vision, policy and strategy, before embarking on the implementation of the lower order elements of the framework.

Figure 4.1 Elements of an enabling framework for overload control

Vision <hr/>	Sets out the country's goals and objectives in the transport sector, including a vision for overload control.
Policy <hr/>	Based on the vision; sets out the policy on overload control. Requires legislative support.
Strategy <hr/>	Develops a strategy for achieving the overload control policy.
Programs <hr/>	Incorporate overload control policy and strategy in national programs.
Plans <hr/>	Detail specific means of achieving overload control programs.
Implementation <hr/>	Ensures agreed <i>plans</i> are implemented within a broader program on overload control.
Monitoring <hr/>	Checks whether the projects have been implemented in a manner that achieves the stated policy on overload control.

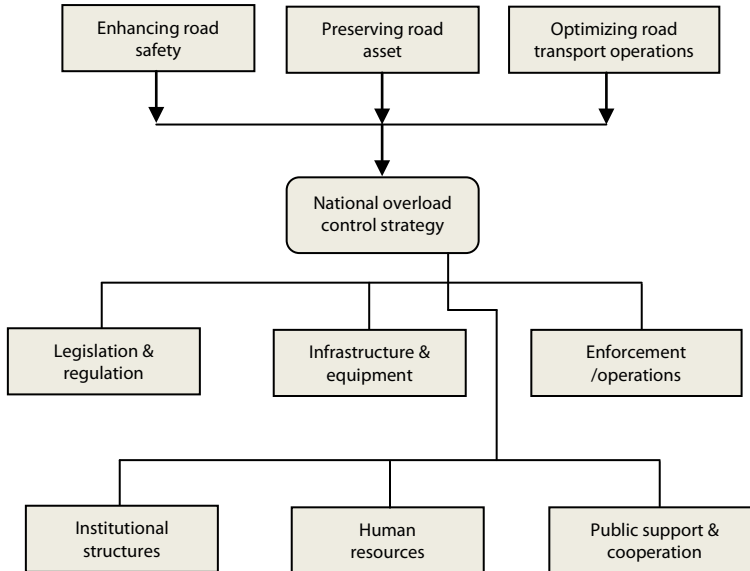
Figure 4.2 Key elements of an overload strategy

4.5 In light of the above, there should be a shared vision on overload control which should be in keeping with that espoused in the SADC Protocol on Transport, Communications and Meteorology, which exhorts member states “to ensure and sustain the development of an adequate roads network in support of regional socio-economic growth by providing, maintaining and improving all roads in order to minimize total road transport costs and to preserve assets vested in road infrastructure”. This implies a need for *physical and operational integration of overload control networks; convergence of policies; joint planning; harmonization of standards and operations; joint cross-border operations; and accession to regional agreements and protocols.*

Strategy

4.6 Figure 4.2 illustrates the various elements of an overload control strategy which, in keeping with the vision of the RECs in Sub-Saharan Africa, aims to:

- Preserve road infrastructure (roads and bridges)
- Enhance road traffic safety
- Optimize road transport operations (including fair competition between modes and operators (“level playing field”))

4.7 In light of the strategy for overload control outlined above, the fundamental issues affecting the implementation of previous proposals are as follows:

- (a) Whether or not there an enabling framework is in place for overload control in terms of the higher order elements of:
 - Vision
 - Policy
 - Strategy
- (b) Whether or not an appropriate strategy is in place for overload control including the following elements:
 - Legislation and regulations
 - Infrastructure and equipment
 - Enforcement and operations
 - Institutional/organizational structures
 - Human resources/training
 - Public support and cooperation
- (c) Whether or not adequate funding is in place to allow the strategy to be implemented.

IMPLEMENTATION BARRIERS AND MEASURES FOR OVERCOMING THEM

4.8 Typical barriers to implementation of previous proposals on overload control and measures for overcoming them are discussed below.

4.9 Issue/Problem 1

Lack of an appropriate enabling framework for overload control

In many countries there is a lack of an appropriate enabling framework for overload control. Such a framework is not only essential for creating the enabling environment within which the role players in the system can view their roles with respect to overload control but, also, for sending out signals, through its policy principles and objectives, which are translated into the legal, institutional and regulatory frameworks governing overload control.

4.10 **Solution 1**

All countries that do not have an appropriate enabling framework for overload control should set about establishing one along the lines indicated in Figure 4.1. This should be achieved through a participatory approach involving both public and private sector stakeholders. National issues on overload control should be viewed within a broader regional context and framework in terms of “thinking regionally, acting nationally”.

4.11 **Issue/Problem 2**

Lack of any policy on, or appreciation of, the importance of overload control at national level

There is often neither a coherent Government policy on overload control in place nor a full appreciation in Ministries of Finance of the adverse impact of overloading on the economy. As a result, low priority is given in many countries to the importance of overload control.

4.12 **Solution 2**

Where no policy on overload control exists, such a policy should be developed by national public and private sector stakeholders led by the relevant national roads authority. Continuous dialogue should be maintained with political and public stakeholders (e.g. transporters associations) in order to sensitize them to the price that the country is paying for ineffective overload control and to obtain their full support for implementation of an effective overload control policy. In order to achieve such support, it is important to quantify and then to highlight to stakeholders the substantial benefits to be derived from implementing such a policy.

4.13 **Issue/Problem 3**

Lack of effective regional coordination

Following the restructuring of SADC, leading to the dissolution of the sectoral commissions such as SATCC, the technical committees have not been active. Thus, although the SADC MLP as well as the COMESA proposals on overload control provide a regional vision for national improvement of overload control, lack of appropriate institutional arrangements at regional level to “drive” the process has resulted in uncoordinated approaches at country level. Moreover, agreements reached

several years ago on how best to deal with implementation of these REC proposals have lost momentum and, as a result, very little progress has been made in improving overload control in many countries.

4.14 Solution 3

Sub-regional organizations, such as ASANRA, whose membership includes the Chief Executive Officers or Directors of Roads of all member states of SADC, should provide catalytic leadership to the region in the dissemination of previously harmonized regional policy on overload control. In so doing, the regional organization should fulfill the role of a champion and driver of the implementation of previously agreed REC policies on overload control.

4.15 Issue/Problem 4

Lack of awareness of REC proposals on overload control

There is still a lack of awareness in some countries of the REC proposals on overload control, such as the SADC MLP on Vehicle Loading. This document takes account of international good practice on various aspects of overload control and includes a number of trend-setting initiatives that represent a fundamental shift in approach to this activity. In so doing, the MLP responds to the most glaring shortcomings of traditional approaches to overload control.

The fundamentals of the MLP embrace all the key approaches to overload control espoused by COMESA and generally remain valid since they were first developed in 1999. The MLP provide some flexibility for customization to country-specific circumstances and, in so doing, they allow countries to include any new developments that may have emerged since they were first produced.

4.16 Solution 4

ASANRA and other similar regional bodies should engender awareness amongst their member states of the existence and importance of the REC proposals on overload control, which should serve as a point of departure for implementation in all RECs.

4.17 **Issue/Problem 5**

Inadequate/outdated legislation

The legislation dealing with overload control is inadequate/outdated in many countries and is deficient in many respects such as dealing with hazardous substances and offering protection to bridges through the application of a bridge formula. Some of the common shortcomings of existing legislation vis-à-vis the SADC MLPs are as follows:

- Current systems provide a criminal response to incidences of overloading which results in very low conviction rates due largely to legal technicalities and the inability of the courts to effectively cope with what are considered “non-serious” cases compared to more serious crime cases. As a result, there are few incentives to not overload.
- In-house operation of weighbridges involving relatively low paid staff has been conducive to bribery and corruption with the result that unscrupulous operators readily engage in such malpractice.
- The criminal response does not provide any institutional controls or financial links between road authorities and actual road damage.
- There is no “price” for overloading and offenders pay little, if any, money to road authorities to compensate for their increased burden of maintenance costs. What they do pay to Government is very low in relation to the cost of the damage done and is not really a deterrent to overloading. Indeed, it pays operators to deliberately overload and pay relatively low fines on “admission of guilt” for so doing.
- Among transport authorities, only the traffic police (and sometimes transport inspectors) have a direct responsibility to control overloading practices. However, their efforts have little deterrent value due to the constraints of the criminal justice system.
- Road authorities, who have a primary responsibility for preserving the road infra- structure, have a limited role in regulating vehicle loading.

The current systems fail to achieve the primary goal of preserving the road infrastructure. Instead, they are characterized by inefficiency and inequities.

4.18 **Solution 5**

- Decriminalization of offences for overloading by handling them administratively and imposing a requirement on the overloader to pay an overloading fee;
- Application of administrative disincentives to combat overloading practices, such as the withdrawal of operating licenses;
- Outsourcing weighbridge operations to the private sector on a concession basis, i.e. embarking on a commercialized public/private sector approach to overload control. Provision of guidance on embarking on such an initiative would be useful;
- Linking the level of imposed fees for overloading with the actual cost of road damage, i.e. imposing economic fees derived from consideration of such factors as pavement damage, level of apprehension, travel distances and a punitive element. Provision of guidance on a rational methodology for determining overload fines would be helpful; and
- Operation of a self-regulatory system which places the onus for overload control on transport operators and freight forwarders. Provision of guidance on the operation of such an initiative would be helpful.

4.19 **Issue/Problem 6**

Lack of harmonization of regulations

There is still lack of harmonization of many regulations including aspects of vehicle mass and dimension limits in ESA as well as lack of a Bridge Formula in many countries. For example, single axle load limits of 8.2, 9.0 and 10.0 tons still prevail in the SADC region. Such differences also occur with tandem, tridem and permissible maximum vehicle/combination masses, not only within RECs but also between RECs. These disparities are very disruptive to the efficient circulation of HGVs within and between RECs, dilute the enforcement process and encourage bribery.

4.20 **Solution 6**

SADC and COMESA should harmonize their recommended axle load and maximum combination mass limits as agreed at the joint meeting that was held in Malawi in 2000 (COMESA agreed to adopt the SADC load limit recommendations). Also, member states of RECs should urgently amend their regulations so as to ensure that their vehicle load limits are in line with the recommended ones.

There should be staged implementation of the recommended limits to enable any existing backlog of pavement or bridge deficiencies to be rectified as well as to allow roads authorities to plan for increased axle loads and vehicle masses in their designs for road pavements or bridges.

The bridge formula should be applied in all countries to control the load intensity of vehicles and, by so doing, protect bridges and structures.

4.21 **Issue/Problem 7**

Inadequate weighbridge infrastructure/equipment

In many countries the existing weighbridge infrastructure is either insufficient, in terms of providing adequate coverage of the road network, or inadequate in terms of being either non-functional, partially functional or unreliable. This applies to many of the first generation 3.2 m x 1 m single axle scales which are prone to inaccurate readings because of level differences between the scale and the concrete approach slabs.

4.22 **Solution 7**

Each country should undertake an inventory and audit of its weighbridge stock and develop a strategy for gradually replacing inadequate weighbridges in accordance with an appropriate strategy. Any planned investment in weighbridges should be undertaken in the context of a long-term vision for overload control in terms of such factors as:

- The eventual coverage of the national road network with various types of weighbridges. In principle, appropriate weighbridges should be available at all strategic points on international/corridor routes

within each country. These should be supplemented with mobile weighbridges to make a complete system.

- The most appropriate type of equipment in relation to traffic levels and location and conformity with the proposed establishment of an integrated network of weighbridges on the main corridors of the region. The location of weighbridges on either side of country borders should be avoided and, as recommend previously at various fora, recourse should be made to joint weighing of vehicles at a border post.
- The ultimate need to strike a balance between investment in weighbridge infrastructure and returns on that investment in terms of a reduced incidence of overloading, and
- As far as possible, weighbridge should be standardized, or at least harmonized, on the main corridors to facilitate training activities.

In addition to the above, the development of a guideline dealing in part with the selection of weighbridge infrastructure would ensure a harmonized approach in the region. The development of such a guideline is one of the outputs of this project.

4.23 **Issue/Problem 8**

Inappropriate selection of weighbridge equipment

A number of countries are embarking on the procurement, installation and operation of weighbridges along their strategic routes. Unfortunately, there are instances where inappropriate equipment has been selected, e.g. a relatively expensive 22 m x 3.2 m multi-deck scale being chosen for a secondary road carrying relatively low levels of traffic (< 500 vpd) or the equipment installation has been inadequate for the function required.

4.24 **Solution 8**

The development of a guideline dealing in part with the criteria to be used for selecting weighbridge equipment in relation to the prevailing environment (type of road, traffic level) would be valuable. The development of such a guideline is one of the outputs of this project. The ultimate aim should be the development of a coordinated network of standardized weighbridges strategically located over the main corridors.

4.25 **Issue/Problem 9**

Variable weighing results

There are often differences in the results obtained from the weighing of vehicles at different weighbridges due to a number of reasons for such variation including:

- Axle attitude variation related to site conditions
- Suspension hysteresis
- Grade effects
- Scale error

Lack of appreciation of the reasons for the inconsistent weighing results obtained at location A in contrast to location B has led to suspicion and acrimony between operators and weighbridge personnel.

4.26 **Solution 9**

Development of a guideline for the standardized weighing of vehicles for enforcement of axle, axle unit, vehicle and vehicle combination mass limits (the development of such a guideline is one of the outputs of this project). Such a guideline should allow for the variations listed above and should provide a sound basis to determine axle, axle unit, vehicle and vehicle combination overloading. The guideline is essential to ensure uniformity in weighing across the region and to engender greater acceptance by transporters of the weighing results.

4.27 **Issue/Problem 10**

Variable determination of vehicle loads

There are many variations in determining vehicle loads in the ESA region. Typical examples include:

- Differences in computing compliance with legal load limits in terms of tolerances allowed. Such tolerances vary from zero percent to generally 5 percent with the allowable tolerance also varying between axles and total vehicle/combination mass. These differences complicate the enforcement process at borders where the tolerance allowed on one side of the border differs to that allowed on the other side;

- Differences in dealing with so called “awkward” or “special” loads such as animals, explosives, etc. In some countries such loads are treated as “normal” loads while in other countries, they are treated “preferentially”. This inconsistency complicates the enforcement process within the region; and
- Weighbridge report forms also vary considerably in terms of being either manually or electronically produced, type of data collected, etc.

4.28 **Solution 10**

Development of a guideline for the standardized weighing of vehicles as regards tolerances to be allowed on permissible axles and vehicle/combination mass. The development of such a guideline is one of the outputs of this project.

Development of a standardized weighbridge report form that would be recognized and honored by all countries in the region. Such a report form would ensure uniformity in the recording and calculation of overloads and overload fees.

4.29 **Issue/Problem 11**

Lack of effective reporting systems

The quality and extent of weighing data that is collected at permanent weighbridges varies enormously amongst countries. As a result, such data is of limited value for broader planning purposes, such as the derivation of vehicle equivalence factors. Moreover, such data is not shared on a regional basis and dilutes the enforcement process in terms of targeting habitual offenders.

4.30 **Solution 11**

An appropriate Overload Control Management System should be installed at all primary weighbridges located at least on the Regional Trunk Road Network. This would improve the effectiveness of the operations in many respects including statistical information on overloaded vehicles by type, commodity carried, etc. A guideline on data collection, analysis and

presentation should be produced to exploit the potential value of the data being collected. Such a guideline is one of the outputs of this project.

4.31 **Issue/Problem 12**

Variable opening hours

In some countries, the opening hours for weighbridge units and Customs are not synchronized with the result that overloaded vehicles simply wait until the weighbridge unit is closed and then proceed to border posts where they obtain clearance for transiting the country without being weighed beforehand.

4.32 **Solution 12**

All countries to ensure that the hours of operation of weighbridge units are synchronized with Customs. Increasingly, border opening hours on the most heavily trafficked corridors in the region are around the clock, i.e. 24 hours per day. This may entail shift operations by weighbridge units.

Based on the positive outcome of the Cross-Border Overload Control System piloted at the Martins Drift/Groblers Bridge (Botswana/South Africa border) all countries should consider introducing similar systems at the borders. Guidance on this system is provided in one of the case studies included in a companion report. In addition, where possible, countries should consider joint weighbridge operations as an integral part of one-stop border post operations.

4.33 **Issue/Problem 13**

Inappropriate institutional structures and inadequate human resources

Many of the institutional arrangements that exist in some countries are not commensurate with the developments that have taken place in overload control and with the advances that have occurred in weighbridge infrastructure technology. For example, the existence of a Weighbridge Unit within a Maintenance Division of a Roads Department manned by relatively junior technical staff may have been adequate for the operation of fairly simple, manually operated scales. However, the use of relatively

expensive, state-of-the-art, computerized infrastructure requires more substantial institutional structures and higher caliber, trained and qualified staff.

4.34 **Solution 13**

Weighbridge operations and institutional structures should be given a much higher profile than hitherto in many countries. Accordingly, an organizational structure for all weighbridge installations should be drawn up showing responsibilities and duties of all personnel involved in the operation, management and enforcement aspects of overload control at weighbridges.

4.35 **Issue/Problem 14**

Inadequately trained human resources

Appropriate training of weighbridge staff in all aspects of weighbridge operations – managerial, technical, legal, and mechanical, etc. – is either non-existent or poorly carried out in many countries. Where it is carried out, it tends to be country-specific and not to embrace developments on overload control technology. This short-coming has been cited by many stakeholders as one of the most serious shortcomings of overload control operations in the region.

4.36 **Solution 14**

Minimum standards of education and training should be set for weighbridge staff at various levels of operation. Such training should be standardized throughout the region and follow a prescribed syllabus. Outputs of such training should be certified and accredited with an appropriate educational establishment.

Maximum use should be made of a regional training institution rather than national or external training institutions. In this regard, a Regional Training Institute should be set up to cater for all SADC and COMESA countries. Finally, a training guideline with an indicative syllabus should be developed for use at regional level. Such a guideline is one of the outputs of this project.

4.37 **Issue/Problem 15**

Lack of public support and co-operation

There is generally lack of support and co-operation for overload control for the following reasons:

- Lack of appreciation or awareness of:
 - The hidden costs resulting from additional wear and tear to their vehicles
 - The negative effects of overloading on the roads infrastructure and the country's economy
 - The way in which road safety is compromised and the lives of the driver and other road users are endangered
- Overload control operations are generally viewed as being carried out by lowly paid, low caliber enumerators who are susceptible to bribery and corruption (there are many instances of bribery and corruption being reported in national newspapers).

4.38 **Solution 15**

Mount an appropriate public awareness campaign involving all stakeholders, including the publication of information booklets and flyers and holding of a national stakeholder workshop involving political leaders.

4.39 **Issue/Problem 16**

Inadequate funding for overload control

There is a general lack of understanding of the level of investment required to implement and sustain effective, comprehensive and long term overload control. This is exacerbated by the low priority accorded to this activity by Ministries of Finance and the resulting inadequate budgets provided.

Figure 4.3 – Sustainability framework for a sustainable overload control system

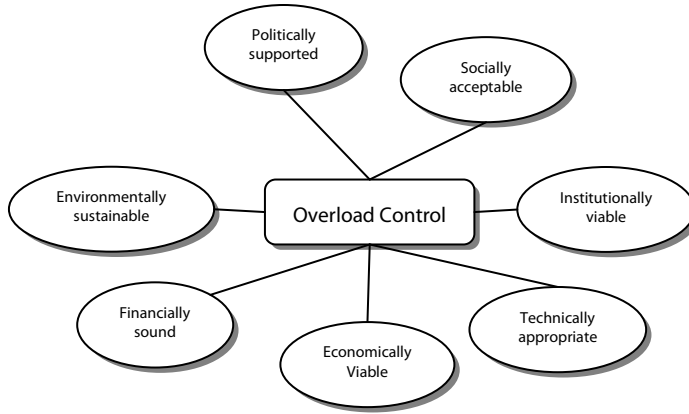

4.40 Solution 16

Sensitize Ministries of Finance and lobby political support for overload control. In addition, utilize Road Fund monies for adequately addressing the financial requirements for overload control.

Key elements for sustainability of overload control

4.41 Experience in the ESA region has shown that for any project to be sustainable in the long run, it should satisfy simultaneously the “seven dimensions of sustainability”. This requirement is no different with overload control, for which the various dimensions are illustrated in Figure 4.3.

4.42 Satisfying just a few dimensions of sustainability, for example, the technical and institutional, without political support or a sound financial plan will most likely not result in a sustainable system in the long term. Unfortunately, this has been the case with most countries in the ESA region. Thus, if the prospects of achieving long-term sustainability are to be improved, then it is critically important that all countries address all aspects of sustainability in overload control as discussed in various sections of this report.

Summary

4.43 This section has presented a wide range of issues and problems in terms of bottlenecks that have adversely affected the implementation of previous proposals on overload control and proposed solutions for overcoming them. The section has highlighted the pre-requisites for successful overload control including an enabling framework with a well enunciated Vision, Policy and Strategy. The various elements of a national overload control strategy were also listed and the importance of achieving sustainability in all aspects of overload control emphasized.

5. EMERGING GOOD PRACTICES WITHIN THE REGION

INTRODUCTION

Background

5.1 There is within the region a number of examples of “good practice” which, in some way or another, have proved to be very efficient and effective over a sustained period of time in some aspect of overload control. These examples all exemplify some aspect of the trend-setting reforms contained in the SADC document Enabling Legal Reform: Control of Vehicle Loading. Unfortunately, the examples of good practice have either not been written up properly or disseminated in the region. This is a pity, as many countries would undoubtedly benefit from the knowledge and application of such examples of good practice in their countries.

Objective

5.2 Against the above background, the main objective of this section is to provide a synopsis of examples of good practice that occur in the region. The intention is not to go into the details of the examples as a specific component of the project will document case studies that fully illustrate these good practice examples. These case studies will be prepared by regional experts and compiled into a separate report for dissemination to all stakeholders in the region.

Good practice examples

5.3 The synopsis of good practice examples being presented in this section are as follows:

- (a) Decriminalization of overloading in Zimbabwe
- (b) Progressive legislation and regulations on control in Namibia

- (c) Privatization of weighbridge operations in the Western Cape
- (d) Self-regulation of vehicle operations (load control, vehicle maintenance and driver wellness)
- (e) Cross-border overload control system

DECRIMINALIZATION OF OVERLOADING IN ZIMBABWE

The traditional approach

5.4 Traditionally, all SADC states have treated heavy vehicle overloading as a criminal offence in their legislation. However, numerous limitations arise from a regulatory approach to overload control that relies solely on the criminal law. It is a common problem that the serious economic effects of overloading are not fully recognized within the criminal justice system. Most states impose spot fines for overloading or, in more serious cases, prosecute overloaders in the courts.

5.5 When cases are prosecuted through the courts, there are often long delays before matters are brought to trial. Once a prosecution is initiated, there is no guarantee that an offender may be convicted. If convicted, there is also no guarantee that an effective sentence with real deterrent value will be imposed, because judicial officers enjoy wide latitude in imposing sentences.

5.6 The level of spot fines is determined either in the law or by the judiciary (magistrates). These tend not to reflect the actual economic cost of the damage caused to road pavements by overloading. As laws tend not to be updated regularly, the erosion of monetary value often means that fines lose their deterrent effect.

5.7 The SADC proposals to introduce administrative controls of overloading aim to overcome the difficulties associated with criminal enforcement. The main feature of the administrative system is the introduction of a range of fees aimed at recovering the quantum of the damage caused by overloading. Because overloading is no longer treated as a criminal offence, but an action with certain economic consequences, there is no need for the involvement of the criminal justice system. The focus shifts to a mechanism to ensure that the operator of the overloaded vehicle pays compensation for the extent to which overloading has damaged the road pavement.

The new approach

5.8 Zimbabwe has been able to greatly improve the effectiveness of its efforts to curb the practice of overloading heavy goods vehicles. This has been achieved by the decriminalization of vehicle overloading and the introduction of administrative adjudication procedures to deal with infringements of the legal mass limits. The country imposed stiff fees for movements of apprehended overloaded vehicles, and generally required on-the-spot off-loading of excess mass.

5.9 Prior to 1993, the incidence of overloading on Zimbabwe's roads was in the range of 35 to 42 percent. By 1996, following the introduction of administrative procedures, etc., the incidence of vehicle overloading had dropped to 6 percent. In 1996, Zimbabwe took the further step of raising axle-load and maximum vehicle mass limits, and rising further, by a factor of five, the penalties imposed for exceeding the new limits. The result, in 1997, was an overload incidence of only 3.5 percent.

The way forward

5.10 The Zimbabwe "formula" might be further enhanced by privatizing the operation of weigh stations. At a regional workshop held in Maputo, Mozambique during 24-26 February 1998, the workshop generally agreed with the approach taken by Zimbabwe, and resolved that the SA TCC- TU prepare an annex to the Protocol along the lines of this approach. The workshop considered, also, that it would be worthwhile to test, through pilot projects, the potential effectiveness of private sector operation of vehicle weigh stations. Preliminary designs were prepared for two weigh station pilot projects. These pilot project designs were presented to the Vehicle Overloading Control Advanced Strategy Meeting (VOCASM) on 29th January, 1999. Following the meeting, revisions were made to reflect the views of the meeting, and a third pilot project was added at the request of Namibia.

5.11 Unfortunately, following the restructuring of SADC, leading to the dissolution of the sectoral commissions, including SATCC, in early 2000, the implementation of these projects fell into abeyance. However, the motivation for their introduction is probably stronger today than it was when first proposed in 2000. This is because the reforms in the road sector promoted by the SADC Protocol on Transport, Communication and Meteorology have resulted in the establishment of

a number of autonomous roads agencies in the region with a strong incentive to improve the efficiency and effectiveness of the transport sector, with a greater focus on asset preservation through improved overload control.

Case Study: Ineffectiveness of the criminal justice system in leading to prosecution of overload offenders on the N4 Toll Road

Trans Africa Concessions (TRAC) was awarded the concession contract for the N4 Toll Road from Pretoria to Maputo in 1997. Heavy vehicle traffic on this route is increasing by up to 10 percent per annum with average daily truck traffic of 1,500.

Lack of effective load enforcement by the State led to the implementation of an overload strategy and operations to minimize pavement damage due to overloading. The following statistics have been compiled since the strategy was implemented in 2002:

• Total fines issued	R83.6 million
• Total fines paid	R24.5 million
• Payment of fines	29%
• Cases withdrawn	14%
• Discount on fines by court	up to 60% (43% of cases)

The above statistics for the period 2002 – 2007 show clearly the ineffectiveness of the criminal justice system in dealing successfully with the prosecution of overloading offenders – a situation that is typical of all countries in the ESA region where reliance is placed on this approach to deal with overloading offences.

Source: TRAC presentation to Maputo Corridor Logistics Initiative (MCLI) meeting, South Africa, October 2007.

PROGRESSIVE STRATEGY ON OVERLOAD CONTROL IN NAMIBIA

Background

5.12 The importance of having an enabling framework in place for carrying out overload control, including an appropriate strategy for achieving government policy, was highlighted in Section 4, paragraphs 4.4 to 4.6. The absence of such a strategy would mean that overload control operations were being carried out in an unstructured and ad hoc manner and unlikely to be efficient and effective. Namibia is one of the few countries in the region that has developed an overload control strategy.

The Namibian strategy on overload control

5.13 The overload control strategy developed in Namibia is based on the recommendations of the SATCC 5 Country Special Working Group on Overload Control Final Report, dated February 1994. At the time only three weighbridges equipped with single axle scales were available for overload control, and were operated by the Traffic Department of the Police. These weighbridges were outdated and lacked spares for their repair and therefore were not in operation for most of the time. The scheduling of overload control operations depended on the priority of the police and therefore overload control was accorded low priority among other traffic control operations.

5.14 Against the above background, a strategy on overload control was developed and included the following elements:

- Development of weighbridge facilities at strategic locations on the network
- Establishment of a cadre of personnel dedicated to overload control and other road safety enforcement
- Maintaining the efficiency and effectiveness of overload control through private sector participation in the management of overload control operations
- Developing a networking system of all the weighbridge facilities for monitoring the operations with little human interventions as possible which lead to malpractices
- Consulting the stakeholders at all stages and particularly educates the judicial system on the implications of overloading
- Encouragement of joint overload control operations across borders and sharing of information
- Introduction of overload fees that fully recover the cost of damage of the road pavement
- Comprehensive training for weighbridge staff in the form of an Advanced Overload Control Course and the issuance of competency certificates which are accepted by the Courts

5.15 The only element of the Namibian strategy that is not yet in place is the decriminalization of overload offences. However, this issue is the subject of an on-

going study with a recommendation to Government to introduce an infringement system in place of the more traditional prosecution system that has had limited effectiveness.

Impact of overload control strategy

5.16 The implementation of the overload control strategy has facilitated the control of pavement consumption and has resulted in improved road safety. There has been a significant reduction in the percentage of overloaded heavy vehicles from 29 percent in 1998 for overloading within the 5 percent tolerance to 10 percent in 2005.

5.17 The positive impact of developing and introducing a sound strategy on overload control has demonstrated in a quantitative manner the obvious benefits of adopting a structured approach to overload control in line with the SADC MoU on vehicle loading.

PRIVATIZATION OF WEIGHBRIDGE OPERATIONS IN THE WESTERN CAPE

Background

5.18 A wide range of options exist for public-private partnerships (PPP) in overload control. Overload control is a hybrid function consisting of various activities. Some activities have traditionally been undertaken by the private sector, such as weighbridge construction, scale manufacture and installation, scale maintenance, etc. Others, such as on-the-road enforcement, are policing functions normally undertaken by the government. Overlapping these activities is a number of functions that both the private sector and government could undertake, such as infrastructure management and maintenance.

Western Cape privatization model

5.19 The model adopted in the Western Cape is the operation of the weighbridge facilities through a management contract. This model was adopted for the following reasons:

- The benefits of involving the private sector are obtained without losing control over operations or ownership of the asset

- The model has inherent flexibility in terms of personnel application, performance measurement and payment
- Only provincial or local authorities can employ traffic officers

5.20 The parties involved are the Employer which is the Transport Branch of the Department of Transport, Public Works and Property Management of the Provincial Administration Western Cape (PAWC), the Contractor and the Employer's Representative or Project Manager. Separate management contracts are entered into for each weighbridge facility.

5.21 **Personnel:** The contractor must supply the following personnel: site manager, supervisor of the weighing team, weighbridge assistant, supervisor of the screening team, screening assistant, site cleaner/gardener and a debtor's clerk. All law enforcement personnel are supplied by the PAWC.

5.22 **Control of staff:** The site manager is in control of the contractor's staff and the Law Enforcement Manager of the law enforcement staff. The Law Enforcement Manager is in the employ of the PAWC. The Law Enforcement Manager supervises the traffic officers take care of the scheduling and deployment, personnel administration, and record keeping and administration. A Project Manager is also appointed by the PAWC to monitor and supervise the project overall and to verify the monthly certificates.

5.23 **Allocation of functions:** The contractor is responsible for all non law-enforcement activities. The contractor's staff must screen and weigh vehicles, collect vehicle data and do RTQS checks and then inform the traffic officer on duty of any offences. Daily operational information must be collected and reported on daily. The contractor receives copies of daily prosecutions and must contact offenders and remind them of payment. The contractor must also do a monthly status report on fines issued, fines recovered and fines outstanding, using information obtained from the weighbridge, provincial and local authorities and the local magistrate court. The contractor must also assist with court appearances. A fine collection clerk stationed at the local court or municipality is proposed. The contractor must further ensure that the weighbridge site is neat and tidy and is responsible for the security arrangements.

5.24 The traffic officers perform the following functions: one officer diverts traffic from the road to the weighbridge, one officer at the weighbridge oversees

the weighing process, charges overloaded vehicles and performs RTQS checks and one officer screens vehicles on the alternative routes.

5.25 **Infrastructure and equipment:** The PAWC provides certain equipment, such as computer hardware, scale equipment, photocopier, radio for communication, furniture as well as the portable screening equipment and temporary road signs for the screening teams.

5.26 The contractor must supply cell phones for the supervisors, e-mail facilities including a modem and telephone line, a fax machine and a computer and software for the debtor's clerk. The contractor must supply cleaning equipment for the buildings, gardening tools for the day-to-day upkeep of the garden, stationery and consumables and a vehicle for the screening team. The maintenance of buildings is carried out by the contractor, but these activities are controlled by the project manager. The maintenance and verification of the scale, repairs to the scale and other equipment and the maintenance of the screening devices are all carried out by the contractor and paid through the contract.

5.27 **Operational periods:** Weighbridges are operated 8 hours/day Monday to Sunday on a flexible basis. The 8-hour shift can be split into two 4-hour shifts.

5.28 **Duration of the agreement:** The duration of the contract is 24 months.

5.29 **Screening of alternative routes:** Screening is performed at predefined locations during the 8-hour shift by one screening team per weighbridge.

5.30 **Payment for services:** Payment for the services rendered by the contractor is done on a schedule of quantities basis. Services such as contract management and co-ordination, provision of supervisors and assistants, debtor's clerk, site cleaner/gardener, office consumables, fax facility, telephone/modem and security services are paid for on a monthly basis.

5.31 The production of the contractor is evaluated on two aspects, productivity and availability. Productivity is evaluated on the processing rate, i.e. the number of vehicles weighed per time period. Availability is a measurement of the working hours of the weighing and screening teams relative to the hours available in a month. The monthly amounts payable are reduced pro-rata if the required production rates are not achieved.

Weighing process showing how private contractor's staff interact with drivers to perform weighing duties



The weighing process starts with one of the operators collecting vehicle information, company name, cargo type, origin and destination from the driver. Information used for database purposes and screening of vehicles.

Note that the operator does this in advance as not to delay the weighing process. The permissible mass of the front axle as limited by tyres and manufacturer's ratings are also collected in this advance screening process.

SELF-REGULATION OF VEHICLE OPERATIONS (LOAD CONTROL, VEHICLE MAINTENANCE AND DRIVER WELLNESS) IN SOUTH AFRICA

Background

5.32 One of the tasks of the South African Department of Transport's National Overload Control Strategy was to investigate the possibility of implementing some form of self-regulation in the heavy vehicle transport industry to complement the efforts of the roads authorities in order to address the problem of overloading. The strategy recognizes that the ability to monitor vehicle loads at origin and/or destination based on operator supplied data, is very attractive, strategic and feasible, and could greatly assist in addressing the problem of vehicle overloading. This could save the trucking industry significant time and costs, and improve the logistics of transporting goods by road.

The Road Transport Management System

5.33 The Road Transport Management System (RTMS) is an initiative to introduce self-regulation in the heavy vehicle transport industry, beginning with a pilot project in the timber industry. The project is an extension of the South African Department of Transport's (DoT) National Overload Control Strategy, which recognizes the concept of self-regulation. This comprehensive program is designed to promote compliance with standards covering driver wellness, vehicle maintenance, load securement and the elimination of overloading. The initial pilot project

was funded by the South African Department of Trade and Industry (DTI) and Forestry South Africa.

5.34 The RTMS is a proactive response to increased levels of prosecution. One of the main objectives of the RTMS is to complement, rather than to replace law enforcement, by changing the mindset of consignors, consignees and transporters in the way they view transport operations and compliance with the regulations.

5.35 Concessions to accredited haulers are being investigated, including:

- Only random sample test weighing at weighbridges, thereby reducing delays in queues
- Discounted insurance premiums and excess payments
- Discounted license fees and toll fees
- The use of Performance-Based Standards (PBS) vehicles to increase payload efficiency as currently used in Australia, through an accreditation system

5.36 RTMS allows industry to regulate itself and protect some of the nation's greatest assets: its roads and the people that come into contact with the heavy vehicle transport industry. It is simply good corporate governance to protect these assets and Forestry SA is being well supported by a number of stakeholders including the haulers.

Implementation results and conclusions

5.37 Since vehicle monitoring commenced in November 2002, the incidence of prosecutable vehicle overloading (overloads greater than 5 percent) in the timber industry has reduced by 24 percent (as of June 2004). Furthermore, the average overload per vehicle has reduced by 14 percent during the same period. These figures are impressive, particularly as only three transport operators have been accredited to date.

Way forward

5.38 There is potential for major economic benefits to the road transport industry in Southern Africa as a whole as a result of the reduction in accelerated road infrastructure deterioration due to overloading, an improvement in road safety and an increase in vehicle payload efficiency.

5.39 In view of the success with the RTMS to date, the South African Department of Transport is attempting to roll out this initiative to other industries, and eventually to establish a national accreditation system for the whole of the road transport industry. Negotiations are currently underway to roll out the RTMS to all industries wishing to take responsibility for transport in the supply chain.



Timber truck operating under the RTMS initiative in South Africa

5.40 Timberland Contracting is the first haulier in South Africa to achieve RTMS accreditation and to date, seven transport operators representing 37 percent (464) vehicles of all road transport in the timber industry have applied for accreditation. At present, nine mills in the South Africa sugar industry, who represent approximately 13 million tons transported by road per annum, have also applied to be included in the program.

5.41 The RTMS has the potential for application in a number of countries in the region focusing not only on timber but other industries such as the quarry, cement and coal industries.

CROSS-BORDER OVERLOAD CONTROL SYSTEM (CBOCS)

Background

5.42 Groblersbrug/Martin's Drift is a major crossing point for overloaded vehicles leaving South Africa north-bound, wanting to avoid the tight controls at Beitbridge and through Zimbabwe. In using the Groblersbrug/Martin's Drift route, trucks pass through South Africa, Botswana and Zambia, none of which are currently enforcing adequate control of overloading. This practice not only accelerates the rate of deterioration of the region's roads and bridges, but also negatively affects the road transport rate structure, to the detriment of law-abiding transporters and railways.

Pilot project

5.43 The objective of the CBOCS pilot project was to improve the effectiveness of the existing overload control operations at the Groblersbrug/Martins Drift (South Africa/Botswana) border post at very little, if any, additional cost by adopting a more collaborative, streamlined and professional approach involving all three organizations operating at Groblersbrug. This would involve the following:

- More clearly defined roles, closer working relationships and streamlining of operations between the Weighbridge Unit, Customs and the Cross Border Road Traffic Agency (CBRTA)
- Reliance on both physical weighing of vehicles and imposition of administrative disincentives and penalties under the SACU MoU
- More clearly defined weighing procedures
- Better documentation of output of weighing procedure (Weighbridge Clearance Certificate)
- More formalized communication procedures between the Weighbridge Unit, Customs and CBRTA

Overload control procedure

5.44 In principle, the process for ensuring that overloaded vehicles do not cross the border would hinge critically on the close cooperation and efforts of Customs and CBRTA in that:

- (a) Customs would require the driver of any commercial vehicle to produce documentary evidence that it is not overloaded, in the form of a Weighbridge Certificate, before attending to the clearance of that vehicle for crossing the border.
- (b) CBRTA officials would monitor the Weighbridge Clearance Certificates issued by the Weighbridge Unit as a basis for applying increasingly punitive administrative disincentives and penalties, where necessary.

5.45 The above procedure would supplement rather than replace the existing criminal procedures in that existing practices to impose Admission of Guilt fines or to summons operators in the case of serious offences would continue.

Implementation and audit of project

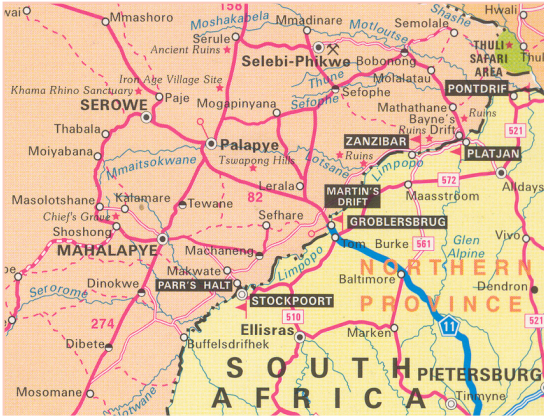

Location of project at Groblersbrug/Martin's Drift border post

5.46 The project was first implemented in December 2004. A review of the operations of the project was undertaken in August 2006, twenty months after it was first implemented. This review revealed the following:

(1) The CBOCS is operating generally in compliance with the minimum requirements of the system design.

(2) The incidence of overloaded vehicles in excess of the 5 percent tolerance has reduced dramatically from a mean monthly value of 8.2 percent to 2.9 percent. There has also been a four-fold increase in the number of vehicles weighed.

Conclusions

5.47 Main conclusions arising from the audit of the CBOCS:

- (1) The pilot project has been a success in that it has achieved the main objective set initially by stakeholders – the reduction of overloading at the Groblersbrug/Martins Drift border post; and
- (2) This success of the CBOCS has been achieved:
 - with benefits to Customs in terms of minimizing the scope for under-declaration of goods on a mass basis; and
 - Without significant additional delays to commercial vehicles.

Way forward

5.48 Based on the outcome of the pilot CBOCS, similar projects should be considered at other border posts in the region.

Integration of good practice examples in a robust overload control system

5.49 The various examples of good practice in overload control described above go some way towards fulfilling many of the key requirements of a comprehensive and robust system. Table 5.1 shows these good practice examples which can be emulated by all countries as well as those gaps in the system that require urgent attention at either REC or regional level.

SUMMARY

5.50 This section has provided a synopsis of examples of good practice in the region, many of which exemplify the trend-setting reform initiatives promulgated by both COMESA and SADC. The examples reflect developments in Namibia, Zimbabwe and South Africa and range from decriminalization of overload control offences (Zimbabwe), an example of a progressive and successful overload strategy (Namibia), privatization of overload control (Western Cape, South Africa), self-regulation of overload control (South Africa) and a cross-border overload control initiative (Botswana/South Africa border). The section concludes that there is potential for application of all of the examples of good practice in other countries in the region as part of a comprehensive and robust system of overload control.

Table 5.1 Integration of good practice examples within a comprehensive OC system

<i>Elements of a robust OC system</i>	<i>Existing good practice to be considered/ (Gaps still to be addressed)</i>
1. Legislation and regulations	
Intra-regional harmonization of vehicle load limits (REC)	<i>(Requires urgent attention at REC level)</i>
Intra-regional harmonization of other regs on OC (REC)	<i>(Requires urgent attention at REC level)</i>
Inter-regional harmonization of vehicle load limits	<i>(Requires urgent attention at regional level)</i>
Inter-regional harmonization of other regs on OC	<i>(Requires urgent attention at regional level)</i>
Decriminalization of OC offences	Zimbabwe case study
Introduction of economically based fees	Practice in countries like Namibia, Zambia, Tanzania
2. Infrastructure and equipment	
Regional coordinated citing of weighbridges (REC)	<i>(Requires urgent attention at REC level)</i>
Standardized calibration of weighbridges (REC)	<i>(Requires urgent attention at REC level)</i>
Standardization of weighbridge equipment	<i>(Requires urgent attention at regional level)</i>
Adequacy of number of weighbridge	<i>(Requires urgent attention at regional level)</i>
Proper installation of weighbridge equipment	<i>(Requires urgent attention at regional level)</i>
Greater cross-border cooperation	Guidelines on cross-border overload control
3. Enforcement and operations	
Harmonization procedures and rules governing OC (REC)	<i>(Requires urgent attention at REC level)</i>
Standardization of weighing procedures	<i>(Requires urgent attention at regional level)</i>
Improved monitoring of compliance	Guideline on weighbridge data collection, analysis and presentation of data
4. Institutional arrangements	
Introduction of self-regulatory system	Case study on self-regulation of overload control
Contracting out weighbridge ops to private sector	Guideline on financing mechanisms, private sector participation and concessioning of weighbridges
Establishment of national structures to oversee OC	<i>(Requires urgent attention at national level)</i>
5. Human resources and training	
Harmonized training on a regional basis (REC)	<i>(Requires urgent attention at REC level)</i>
Adequacy/capacity of human resources	<i>(Requires urgent attention at national level)</i>
5. Public awareness and cooperation	
Educational campaigns	<i>(Requires urgent attention at national level)</i>

6. NATIONAL AND REGIONAL INSTITUTIONAL ARRANGEMENTS FOR IMPLEMENTATION OF AGREED STRATEGIES

INTRODUCTION

Background

6.1 Appropriate national and regional institutional arrangements are a prerequisite for effective implementation of agreed strategies on overload control. In the review of previous documentation on overload control that was presented in Section 3, one of the concerning conclusions reached was that although there was widespread acceptance of agreements on overload control reached at meetings and workshops, implementation was generally very poor. This does point to the appropriateness of the national and regional institutional arrangements that have been in place for implementing agreed strategies.

Objectives

6.2 Against the above background, the main objective of this section is to review the national and regional arrangements for implementation of agreed strategies. Based on the outcome of this review, recommendations are made as to how these arrangements can be improved.

INSTITUTIONAL ARRANGEMENTS

Role and function of stakeholder organizations

6.3 Ideally, the inter-relationship between the various stakeholders organizations involved in overload control should be as illustrated in Figure 6.1. The need for such an enabling framework was highlighted in Section 4.4. The framework provides a structured process by which the ESA region's vision for overload control can

progress in a harmonized manner from the policy stage to implementation and monitoring at national level via appropriate programs and plans.

Figure 6.1 Inter-relationship of stakeholder organizations involved in overload control

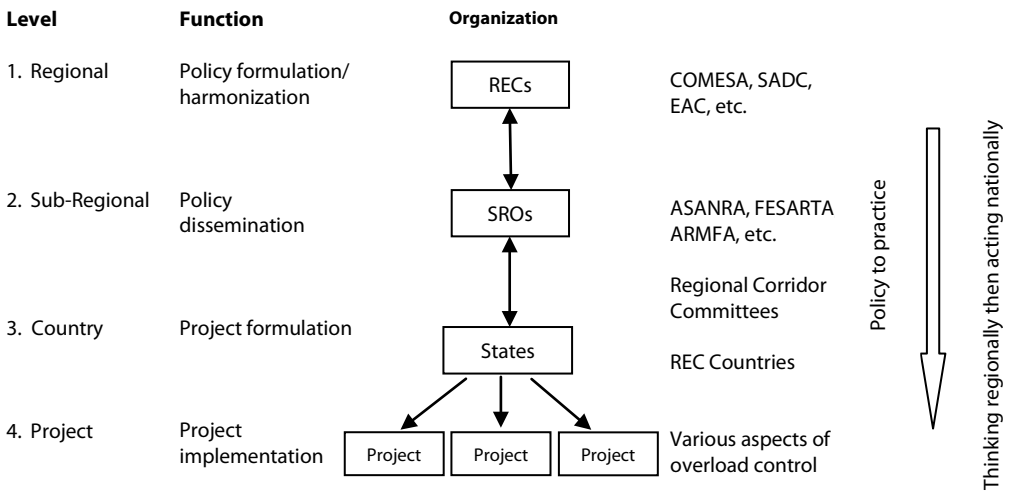

6.4 In principle, there should be clearly demarcated roles, functions and responsibilities of the stakeholder organizations as described below:

- **Level 1 (Policy formulation and harmonization):** comprises RECs (COMESA, SADC, EAC, etc.) that are responsible for policy formulation and harmonization of all aspects of overload control. In so doing, the key function of these organizations is not only to harmonize their policies, but also to disseminate these policies to the next link in the implementation chain, the Sub-Regional organizations.
- **Level 2 (Policy dissemination):** comprises sub-regional organizations (ASANRA, ARMFA, FESARTA, etc.) that are responsible for policy implementation as directed by the RECs. The SROs ensure that any overload control programs proposed for implementation by their respective member states are fully in accord with the harmonized policy direction provided by the RECs.

- **Level 3: (Project formulation):** comprises formulation of projects at national level by national organizations (usually the road authorities) for endorsement by the SROs in line with REC policy.
- **Level 4: (Project implementation):** Involves implementation of projects at national level that are fully in accordance with the harmonized policy directed by the RECs.

Previous arrangements

6.5 Figure 6.2 shows the Protocol Implementation Institutional Framework that existed before the restructuring of SADC in 2000. Prior to 2000, SATCC was one of the sectoral commissions that reported directly to SADC and had its technical arm, the Technical Unit that was responsible for dealing with a variety of technical issues, including overload control.

Figure 6.2 SADC Protocol Implementation Institutional Framework

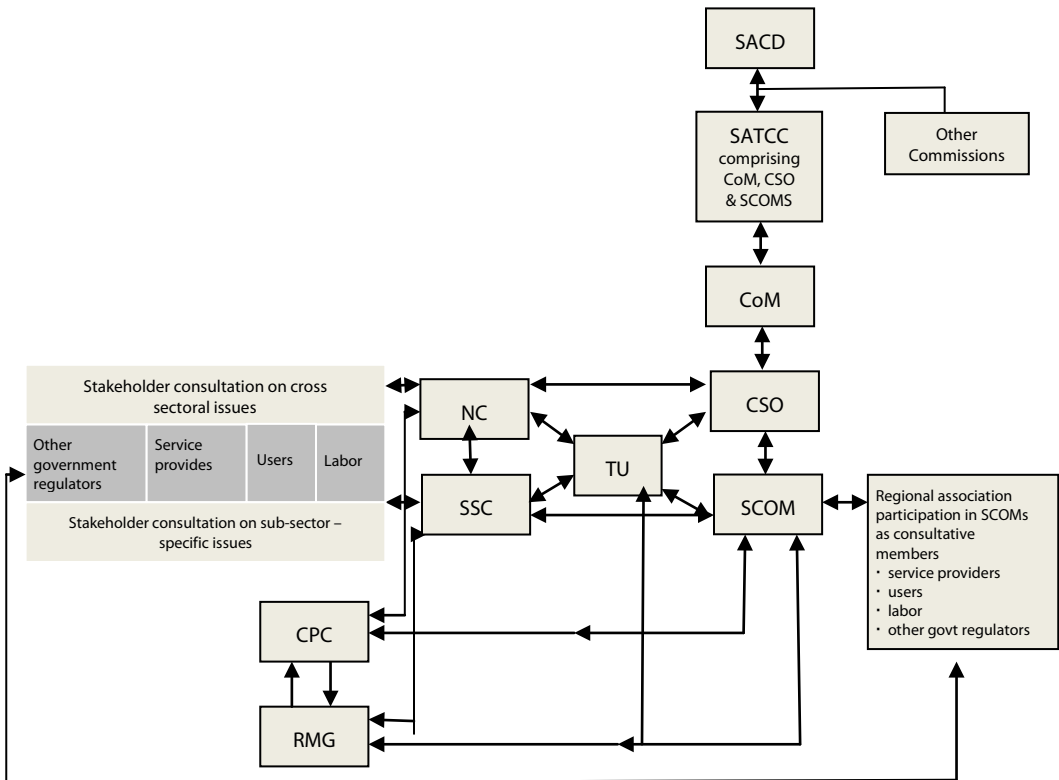

6.6 The key elements of the Protocol Institutional Framework were as follows:

- (a) National Protocol Coordination Teams comprising:
 - a. A national coordinator nominated from the ranks of subsectoral coordinators
 - b. subsectoral coordinators for a number of sub-sectors, including Integrated Transport, Roads, Road Transport and Road Traffic
 - c. Deputy subsectoral coordinators
- (b) SATCC Integrated Transport Committee (ITC) at the regional, subsectoral level
- (c) Corridor Planning Committees and Route Management Groups

6.7 In the above arrangements, national and sub-sectoral coordinators and their deputies took the lead in implementation of agreed policies. They were the link between Member States, the sub-sectoral committees (SCOMS), and the Technical Unit and served as national agents for promoting Protocol implementation and monitoring.

Review of performance

6.8 In theory, the Protocol Implementation Institutional Framework was ideally suited to ensure implementation of the SADC protocol on Transport, Communications and Meteorology, including the various annexes to the protocol such as the SADC MoU on Vehicle Loading and the Model Legislative Provisions on Management of Vehicle Loading.

6.9 In practice, the degree to which the various provisions of the Protocol were implemented was largely dependent on the commitment and energy of the leaders of the national structures – i.e. the national and sub-sectoral coordinators. This commitment and energy varied widely in the region with some leaders being pro-active and others reactive. Nonetheless, the potential for implementation was facilitated by a well conceived Protocol Implementation Framework.

Implications of restructuring of SADC

6.10 As indicated in Section 4, following the restructuring of SADC, leading to the dissolution of the sectoral commissions, such as SATCC, key elements in the Pro-

tol Implementation Framework such as the SCOMS, the National Coordinator and the sub-sectoral committees, have not been active. Thus, the institutional arrangements at regional or national level to “drive” the overload control process have become blurred and need to be formalized.

PROPOSED NEW ARRANGEMENTS

Level 1 – regional coordination

6.11 Notwithstanding the existing arrangements for inter-REC coordination, those on overload control need to be strengthened so as to ensure a coherence, convergence and harmonization of policy through appropriate policy instruments such as joint policy directives. These directives should then be disseminated to the SROs such as ASANRA, or in those RECs where such organizations do not exist, to the roads authorities responsible for overload control.

Level 2 – sub-regional coordination

6.12 At a meeting of Surface Transport Experts that was held in South Africa in April 2007, the role of regional bodies such as ASANRA and FESARTA was reviewed and it was resolved that such bodies should be elevated as specialized agencies of SADC and should play a key role in facilitating implementation of harmonized policies agreed at regional (REC) level. In this regard, ASANRA would have a key catalytic role to play in coordinating and facilitating the implementation of the SADC MoU on Vehicle Loading. Such a role is well suited to this regional association whose membership includes key decision-makers in the roads sector in the form of the Chief Executive Officers or Directors of Roads. Moreover, as indicated in Figure 6.3, ASANRA’s organizational structure, through its Committee on Construction and Maintenance is well placed to fulfill the role of a specialized sub-committee on overload control.

6.13 In RECs other than SADC where regional organizations similar to ASANRA may not exist, such RECs should consider establishing similar bodies as, without them, it will be more difficult to achieve the desired regional integration and coherence of the overload control programs.

Figure 6.3 Organizational structure of ASANRA

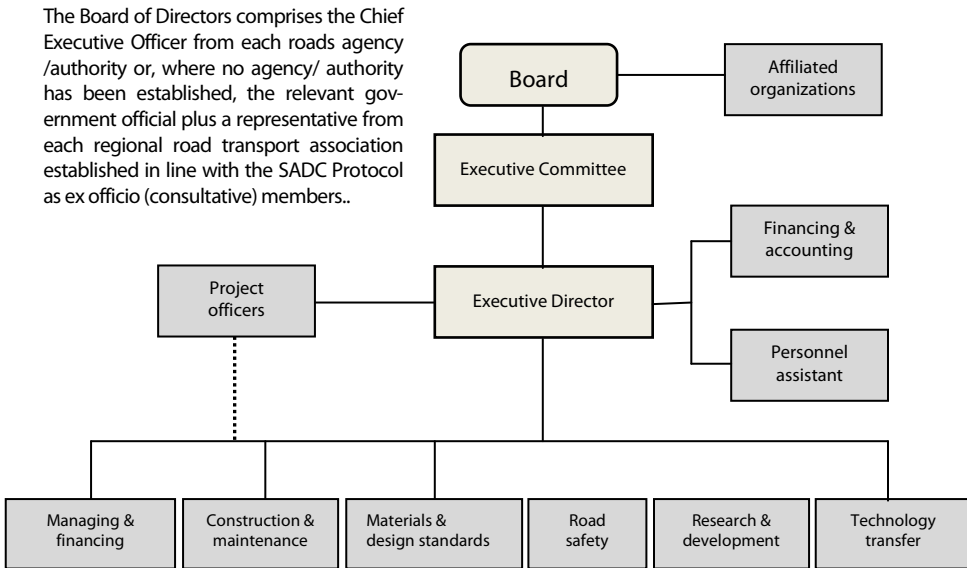

6.14 The envisaged future role of ASANRA in overload control would obviate the need to establish a separate Regional Vehicle Overload Control Association (REVOCA) as proposed by SATCC at the Inaugural Meeting of the REVOCA that was held in August 1999 (See Annex, paragraph 25). This proposal was put forward before the establishment of ASANRA and the restructuring of SADC.

6.15 The role of Corridor Management Committees in overload control remains an important one at regional level. These committees are constituted of specific Working Groups which include both public and private sector stakeholders and are ideally placed to facilitate implementation of agreed policies at the interface between a REC and its member states. For example, the Northern Corridor Management Committee includes representatives of all EAC countries and plays a key role in facilitating the coordination of overload control matters on that corridor.

Level 3 – national coordination

6.16 **Previous arrangements:** Vehicle overload control matters at national level have typically been handled by a government Roads Department or Roads Authority often without the direct involvement of other key private sector stakeholders such as

transporters' associations or freight and forwarding agents. Moreover, there has generally been inadequate coordination between national and regional bodies on overload control matters. Thus, there is much scope for streamlining roles and responsibilities of stakeholders at national level in a more inclusive manner than hitherto as well as formalizing linkages with SROs.

6.17 In principle, the composition, role and responsibilities of a Vehicle Loading Advisory Committee (VELAC), as envisaged by the SADC MLP, is well suited to ensuring a more participative and structured approach to overload control as proposed in section 6.5. The VELAC organizational arrangements proposed for adoption at national level are presented in Figure 6.4.

Figure 6.4 – Proposed institutional arrangements at national level

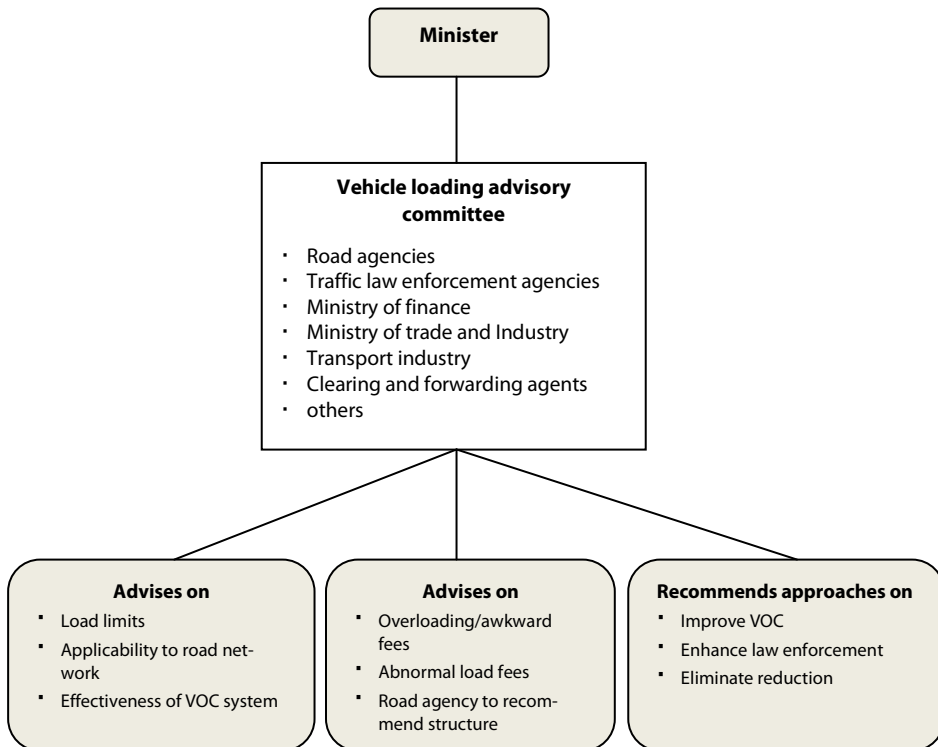

SUMMARY

6.18 The previous Protocol Implementation Institutional Framework provided the mechanisms for effective implementation of the SADC Protocol on Transport, Communications and Meteorology including the annexes dealing with overload control. In practice, success with implementation of the SADC MoU on Vehicle Loading was largely dependent on the commitment and energy of the leaders of the national structures. With the restructuring of SADC many of the key committees, with the exception of the Corridor Management Committees, have not been active.

6.19 New institutional arrangements have been proposed providing a structured process by which the ESA region's vision for overload control can progress in a harmonized manner from the policy stage to implementation and monitoring at national level via appropriate programs and plans. This will require strengthened inter-REC coordination and harmonization of overload control policy.

6.20 The emergence of ASANRA in 2002 as a regional association places that organization in a strong position to assume the mantle of a regional catalytic driver and coordinator of overload control in the region through its Committee on Construction and Maintenance.

6.21 At national level, there is generally a need for stronger, more inclusive coordination of overload control matters for which the establishment of a VELAC comprising both public and private sector stakeholders is recommended.

7. TECHNICAL OPTIONS FOR DEALING WITH VARIOUS ASPECTS OF OVERLOAD CONTROL

INTRODUCTION

Background

7.1 Previous sections of this publication have highlighted a number of aspects of overload control practice where there is scope for improvement. Typical examples include improvement of current approaches to enforcement practice and data collection to moving from penalties based on a flat fee basis to those based on a progressive fee system that reflects the economic cost of overloading. However, before changes to the status quo are made, it is very desirable that decision-makers are fully conversant with the underlying principles that guide these changes.

Objectives

7.2 Against the above background, the main objective of this section is to propose technical options and guidance in the following aspects of overload control in the region:

- Vehicle load limits
- Enforcement issues
- Weighbridge infrastructure
- Management aspects
- Financing aspects
- Penalties
- Human resources and training
- Public awareness and cooperation

HARMONIZATION OF VEHICLE LOAD LIMITS

Rationale for harmonization

7.3 Harmonization of axle load and maximum vehicle/combination mass limits is essential to the attainment of an integrated and efficient road transport industry in the region. This is particularly the case as intra-regional trade is expanding and many countries share a number of common borders with adjacent countries. Thus, vehicle load limits should ideally be the same at least amongst the countries of the same regional grouping.

7.4 Unfortunately, as indicated in Section 3, there is still lack of harmonization of vehicle load limits, not only within economic groupings but also, between them (ref. para. 3.14 and Tables 3.2 and 3.3). These differences drastically inhibit smooth and efficient intra-regional goods movement, especially at border crossings, and also unnecessarily complicate the enforcement process. In addition, the cost of under-loading due to differences in axle load limits can be quite significant. For these various reasons, *there is now an urgent need to ensure that vehicle load limits (as well as dimensions) are governed by standardized regulations among the economic groupings and countries of the region.*

ENFORCEMENT ISSUES

Introduction

7.5 The goal of overload control enforcement is to protect the road infrastructure and to promote road safety. To protect the road infrastructure it is necessary to ensure that the forces exerted by vehicles on the road infrastructure, such as the pavement layers and bridges, are not in excess of what the road infrastructure was designed for. To promote road safety it is necessary to ensure that the forces exerted on the vehicle by the load it is carrying, are not in excess of what the vehicle was designed for.

7.6 Regulations controlling the loads on vehicles therefore have to deal with both these aspects and the enforcement of the regulations dealing with both aspects must take place.

7.7 Regulations dealing with the protection of the road infrastructure prescribe the maximum load on axles and axle units, to protect the road itself, but also prescribe the maximum load on vehicles and combination of vehicles to protect bridges. A further protection of bridges is through regulations that aim to ensure that the forces exerted by vehicles on bridges are not too concentrated. These regulations are usually referred to as the “bridge formula”. Many countries do not include a bridge formula in their regulations. This shortcoming should be rectified as soon as possible.

7.8 Regulations dealing with the promotion of road safety limit the loads on vehicles to the values for which the vehicle was designed, such as the manufacturer’s ratings for axles, axle units and the total vehicle, the tyre manufacturer’s ratings and the load on the vehicle in relation to the engine power of the vehicle. Further safety aspects to deal with are the load on the drive axle of a vehicle in relation to the total load on the vehicle and the minimum load on the steering axle.

7.9 For effective overload control regulations dealing with all these aspects must be in place and must be enforced. The regulation which prescribes the smallest permissible mass is the one that determines the legal mass for an axle, axle unit or total vehicle or vehicle combination for a particular vehicle. Some country’s regulations deal only with limits to protect the road infrastructure and do not consider either the maximum allowable load to protect bridges or road safety load limits on tyres and vehicles. These shortcomings should be rectified as soon as possible.

Screening

7.10 Screening is the process according to which vehicles that are probably overloaded are identified on the road so that they can be referred to a weighbridge. Screening should be performed for the following reasons:

- To increase the productivity of weighing sites by wasting as little time as possible on legally loaded vehicles.
- To prevent legally loaded vehicles from being unnecessarily delayed.
- It is an effective method to control corruption and bribery as incidents of overloading are recorded and have to be accounted for, and
- Officers can be monitored for effectiveness and productivity.

7.11 Screening can either be done through observation or by using screening devices. Experienced traffic officers can ascertain through observation whether a vehicle is overloaded or not, by taking note of aspects such as the appearance of the springs or tyres; the sound of the engine up ridges, hills and inclines; and the amount and type of load that is transported in relationship to the vehicle that is transporting it.

7.12 Screening devices commonly involve dynamic mass determination, also referred to as weigh-in-motion (WIM), where weighing takes place while the vehicle is in motion. Low-speed, medium speed and high-speed WIM is available. Portable scales are usually used for LSWIM, while fixed installations are used for MSWIM and HSWIM. A HSWIM installation is shown in Figure 7.1.

Figure 7.1 - General layout of high speed weigh-in-motion site



Referring vehicles to a weighbridge or traffic control center

7.13 When screening is done on alternative routes it is necessary to refer vehicles to a weighbridge or TCC. In many cases it would be necessary for traffic officers to escort vehicles to the weighbridge. The distance that a vehicle can be sent to a weighbridge should be reasonable. No fixed guidelines currently exist in this regard. The use of electronic tracking devices is currently being implemented at a weighbridge in South Africa.

The application of tolerance

7.14 One of the principles of adjudication is that the law does not concern itself with trifles. For that reason a tolerance is granted which permits small bona fide errors that the operator may make during the loading of the vehicles. Scales also do not always give a 100 percent accurate reading and for this reason, most countries allow a 5 percent tolerance on both axle loads and total vehicle/combination mass. However, experience in South Africa has shown that a number of operators were deliberately exploiting the vehicle/combination mass tolerance to load beyond the 56 tons permissible maximum combination mass limit without being charged for overloading. For this reason, the 5 percent tolerance on vehicle/combination mass has been reduced to 2 percent in South Africa while that on axles was retained at 5 percent. Nonetheless, consideration should be given to adopting these limits in the ESA region.

7.15 The justification for the reduction in vehicle/combination mass tolerance is that scale accuracies have improved vastly in recent years due to advances in technology and regular verification of scales can result in weighing accuracies above 99 percent (translating to an error of less than 1 percent). In fact, during a survey of 57 weighbridges in South Africa in 2002, it was found that all the combination mass readings fell within the range - 0.88 percent to +0.76 percent of the average combination mass.

Seizure and arrest

7.16 In cases of severe overloads the driver should be arrested and the vehicle seized if it is practically possible. The definition of "severe overload" must be established and must be standardized throughout the ESA region.

Parking and load adjustment

7.17 All overloaded vehicles that exceed the permitted tolerance should be forbidden to travel further until the load has been adjusted. This should be the standard practice at all weighbridges. The level to which the load is adjusted must also be standardized. In some cases it is required that the load be adjusted back to the legal limits, i.e. no tolerance is applied. In other cases it is required that the load be adjusted to within the legal limit plus the tolerance. It should also be standard practice that no loads are allowed to be off-loaded onto the ground at a

weighbridge, but should be transferred to another vehicle. Every weighing facility should be able to notify the operator of a vehicle that his vehicle is overloaded and that the vehicle will not be permitted to travel any further unless the load is adjusted.

Cooperation with the judiciary

7.18 An important part of the overload control strategy is the court system. This could be a major obstacle to effective overload control if the cooperation of the judiciary is not obtained. Court officials should be educated on the importance of the prosecution of overload cases to reduce road damage and to promote road safety.

Additional offences to be concentrated on

7.19 The initial emphasis at weighbridges is to bring the incidence of overloading of heavy vehicles under control. However, the elimination of a wide spectrum of traffic and transport offences should eventually be provided for. Once the overloading offences have been normalized, other priorities should be identified and targeted. These other aspects to be concentrated on are listed below.

- Drivers: Driver's license, professional driver's permit (PDP), public driver's permit (PDP), alcohol, seat belts, outstanding warrants of arrest, etc.
- Operators: Registration, operator's card, outstanding warrants of arrest, appropriate documentation, etc.
- Vehicles: Registration, vehicle license, number plates, load, dimensions, road worthiness (brakes, tyres, lights, oil leaks, noise, emission of smoke and vehicle plates), stolen vehicles, etc.
- Cargo: To ascertain legality of cargo (i.e. check for stolen goods as well as compliance with HAZCHEM or dangerous goods transport regulations), abnormal loads (check compliance with permit requirements).

Verification and maintenance of equipment

7.20 Failure to maintain and verify the weighing equipment could lead to failure of cases in court. Realistic verification intervals need to be established and adhered to. Requirements in terms of record keeping of all verification and maintenance activities must be standardized. Standards for the verification of scales need to be set as well as the requirements that organizations doing verification must comply to.

Accountability of the operator, consignee and consignor

7.21 The normal practice in overload cases is to fine the driver of the vehicle and in cases of severe overloading it is also the driver of the vehicle that is arrested. In many cases the driver however has no control over the loading of the vehicle. For this reason the operator or owner of the vehicle is also held responsible for the correct loading of his vehicles in some countries. The consignor and consignee of the goods being transported are in some instances responsible for the loading of the vehicles. The inclusion of consignors and/or consignees in the responsibility for ensuring the correct loading of vehicles has therefore been supported by the road freight transport industry as well as the law enforcement and road authorities for some time. In South Africa, legislation is currently being amended to include consignors and/or consignees in the responsibility for ensuring the correct loading of vehicles. Consideration should be given to making this the standard practice throughout the ESA region.

Required uniform policies and procedures

7.22 It is desirable that similar procedures are followed at all weighbridges in the ESA region. Uniform policies and procedures should therefore be available at all weighbridges. Apart from the general weighing and prosecution procedures there are a number of “special” cases for which standard policies and procedures should be developed.

7.23 These required policies and procedures include the following:

- Vehicles carrying livestock
- Vehicles carrying hazardous materials/dangerous goods
- Buses

- Sealed containers
- Perishable goods
- Agricultural produce
- Moving loads, such as liquids
- Light vehicles
- Vehicles with an indivisible load: Vehicles of which the load cannot be separated should obtain an abnormal load permit for the entire route before they are permitted to travel any further at the discretion of the roads authority. The permit should cover the whole route and not only the route from the weighing facility
- Containers: A traffic officer can break the seal when he has reason to believe that it contains a divisible load

7.24 Every weighing facility should be able to notify the operator of a vehicle that his vehicle is overloaded and that he will not be permitted to travel any further unless the load is adjusted.

- No loads may be off-loaded at the weigh site on the ground
- Operators must contact another vehicle to take the excess load
- Both vehicles must be weighed before the vehicles are allowed to continue

Dealing with abnormal loads

7.25 In some cases vehicles and loads cannot reasonably comply with the normal legal mass and dimension requirements. Such vehicles and loads are classified as abnormal. The normal practice is for such vehicles to be granted exemption permits. The granting of an exemption permit involves an administrative procedure and usually the payment of a fee, which could be significant in the case of larger loads.

7.26 Standard policies and procedures are required to deal with abnormal vehicles and loads and must address the procedures for applying for permits, conditions attached to the granting of permits, the fees payable, types of permit; how to deal with vehicles/operators not complying with the permit conditions and the

recognition of permits issued by one authority by other authorities and the sharing of the fees payable amongst the authorities.

7.27 Vehicles transporting abnormal loads should, as far as possible, be weighed just like normal vehicles. Weighing facilities should therefore be designed taking this into consideration. The placing of the scale relative to other buildings and structures and the area surrounding the scale should make it possible to weigh abnormal vehicles. If the scale is not wide enough to weigh the whole vehicle, it should be possible to weigh the one half of the vehicle and then the other half.

WEIGHBRIDGE INFRASTRUCTURE

Types of weighbridges

7.28 There are various types of weighbridges, each with its own particular characteristics and each being used for a specific purpose depending on the objective of the weighing exercise. Table 7.1 shows the characteristics of the main types of weighbridges in relation to the method of weighing adopted.

Table 7.1 Weighbridge characteristics

Type of weighbridges		Fixed weighbridges	Mobile weighbridges
		Method of weighing	<ul style="list-style-type: none"> • Easy to operate • Minimum personnel • Cargo off-loading • High installation costs • Limited placement
Static	<ul style="list-style-type: none"> • More precision • Accepted for legal enforcement • Slower 	<ul style="list-style-type: none"> • Easiest to operate • Highest level of precision • Can weigh and register axle groups 	<ul style="list-style-type: none"> • Lowest investment • Optimal for enforcement
Dynamic	<ul style="list-style-type: none"> • Rapid monitoring • Lower precision • Not acceptable for enforcement 	<ul style="list-style-type: none"> • Rapid monitoring • Requires large installation • Requires careful direction of vehicles • Generally not accepted for enforcement 	<ul style="list-style-type: none"> • Minimum disruption of commercial traffic • Lowest accuracy • Excellent for statistical monitoring

7.29 **Fixed weighbridges:** Where the traffic volumes warrant it (traffic > 500 vpd) a multi-deck scale consisting of four individual decks with lengths of 3 m, 6 m, 7 m and 6 m respectively, giving an overall length of 22 m, with a width of 3.2

m should be provided. Each deck must be capable of weighing a maximum mass of 40,000 kg, giving a total weighing capacity of 160,000 kg.

7.30 A standard requirement at all weighbridges should be a roof over the scale. This will improve the working conditions and will make it possible to do weighing in all weather conditions.

7.31 Some of the benefits of multi-deck scales are as follows:

- Level tolerances on the approach slabs are no longer a problem as the whole vehicle is weighed at once;
- It is very quick to weigh a vehicle;
- Short verification tests can easily be done without test weights (measure any axle or axle unit on each of the weighbridge decks and the results should be consistent); and
- It is more difficult to “manipulate” the weighing process, as the whole vehicle is weighed in one go (with an axle unit scale it is easy to weigh only part of an axle unit or to weigh one unit twice and skip an overloaded unit).



Brakwater weighbridge Namibia – 3.2 x 22 m multi-deck scale

7.32 Where traffic volumes (traffic < 500 vpd) do not warrant a multi-deck scale, the weighbridge would primarily be equipped with an axle unit scale consisting of a single deck 3.2 m wide and 4 m long being capable of weighing a maximum mass of 40,000 kg.

7.33 Single axle scales have to be constructed to very precise level requirements which are not easily met. Tests conducted by the CSIR have shown that a

small level difference between the scale and the concrete approaches can result in inaccurate readings, especially when weighing axle units. Weighing of multi-axle trucks is cumbersome and time consuming when using an axle scale. Due to pressure from the courts with regard to the accuracy of these scales/sites it was decided to upgrade the majority of the sites to “axle unit scales” in South Africa. It is recommended that every effort be made to phase out single axle scales for prosecution purposes.



3.2 m x 4 m axle unit scale – Zeerust, S. Africa



3.2 m x 1 m single axle scale – Pioneer Gate, Botswana

7.34 Axle unit scales have largely taken the place of the single axle scale. Some of the benefits of the axle unit scale are as follows:

- They can weigh any axle unit of a truck (i.e. single, tandem or tridem unit)
- Level tolerances on the approach slabs no longer have to be as accurate as for the single axle scale
- Testing the scale is far more simple (limited staking of test weights)
- It is far quicker to weigh multi-axle vehicles

7.35 The size and cost of weighbridge facilities can vary considerably depending on the level of requirement:

- Small office or many offices (i.e. used as a regional office as well)
- Brake testers
- Size of park-off area
- Canopy over the weighing area for protection against weather
- Staff accommodation facilities

7.36 Although a four deck scale is more expensive than an axle unit scale (approximately double the cost), the cost of the scale compared to the total cost of the facility is small (between 8 percent and 18 percent).

7.37 **Electronic equipment and software:** Computer hardware should be provided at each weighbridge loaded with software to control the scale. In the case of weighbridges that are not operated on a 24-hour basis and where security is a problem, it would be advisable to provide a laptop computer that can be removed to a safe place when the weighbridge is not in operation. A laser printer must also be provided to print the weigh tickets. At weighbridges that are operated 24-hours a day and other weighbridges where the number of heavy vehicles is high, a traffic contravention/prosecution system should also be installed. This system should be installed on a separate computer linked to a separate dot matrix printer to print the notices. Where authorities have a central vehicle registration database (e.g. in South Africa it is the NaTIS system), a link should also be provided at each weighbridge.

7.38 The computer system should be connected to all weighing equipment installed at the weighbridge to record the data produced by this equipment automatically. A software package should be installed that can take the readings from the scale directly and the data from the vehicle and driver that is manually entered to calculate whether any axle/axle unit and/or the vehicle are overloaded.



Vehicle load control center, Brakwater



Digital display of actual and permissible masses

7.39 The integrated management information system should store all data generated at the weighbridge in a chronological order. A reporting system, to monitor the operations at the weighbridge, must be implemented to promote efficiency and effectiveness in management of the overload control and other traffic

law enforcement operations. This report should contain details of overload control activities, vehicles weighed and RTQS activities that should be included in a monthly monitoring report.

7.40 A facilities and equipment report should also be prepared on a monthly basis. This report should contain information on the condition of the infrastructure and equipment at the weighbridge, problems experienced and the actions taken to affect repairs and maintenance. Every disruption in the weighing activities should be recorded to create the necessary procedures to resolve problem areas as quickly as possible.

7.41 For security purposes and to minimize malpractice, surveillance cameras should be installed at all weighbridges. One camera should be installed inside the scale house, and a second camera outside at the scale.

7.42 **Manual weighing:** Manual weighing requires no computer equipment, other than a calculator. There is therefore no capital and maintenance cost for computers. Weighing cannot be interrupted due to computer failure. Manual weighing is however time consuming and is only feasible where low volumes of vehicles are weighed. It is easier to make calculation errors, but the advantage is that the traffic officers must fully understand all the regulations to be able to do the calculations. Usually, weighing data is not captured and stored.

7.43 Electronic weighing is fast (at the Kroonstad weighbridge in South Africa, for example, up to 60 vehicles have been weighed in an hour). It however requires computer equipment that must be maintained and if such equipment fails, then weighing usually stops. The operators must be computer literate. Calculation errors are eliminated and weighing data is captured and stored and can be used for reporting and trend analysis, identification of frequent offenders, productivity of the site, etc.

7.44 **Weigh-in-motion equipment:** Weigh-in-motion systems are increasingly being installed at the larger weighbridge facilities. The main purpose of these systems is to monitor overload trends. The systems are also used extensively for screening overloaded vehicles from the main stream of traffic which reduces the number of legal vehicles being delayed at the static weighing facility. It is more appropriate on high volume roads, but can also be effective on lower volume roads for both screening and traffic data collection. The use of HSWIM equipment will lead to less legal vehicles being weighed statically. The total number of vehicles that

has to be weighed at a weighbridge will therefore be less and a smaller facility may then be adequate. The HSWIM equipment can also provide valuable traffic data that can be used to monitor trends and to schedule shifts to ensure the maximum effect. The information can also be used by other departments, such as for long term road planning and maintenance planning.

7.45 **Satellite stations:** At locations where there are a number of alternative routes to cover, which carry a significant amount of heavy vehicles, satellite stations that can be used for screening and monitoring purposes are appropriate. Overloaded heavy vehicles cannot be prosecuted or detained at such satellite stations. Such vehicles would have to be sent or escorted to a weighbridge where they can be weighed statically and charged and be detained. The use of satellite and other electronic tracking devices to monitor the movement of vehicles from the satellite stations to the weighbridge are currently being introduced at some weighbridges in South Africa. This removes the need for traffic officers to escort such vehicles to the weighbridge.

7.46 These satellite stations can be in the form of a permanent lay-by, with all heavy vehicles moving through the lay-by. Where traffic volumes are higher, the lay-by is equipped with a medium-speed weigh-in-motion scale (MSWIM). If the MSWIM indicates that the vehicle is not overloaded, the vehicle will move back to the main road. If it might be overloaded, it is directed to a low-speed weigh-in-motion scale (LSWIM) where it will be weighed more accurately. If the LSWIM shows that the vehicle could be overloaded, it is directed or escorted to the weighbridge.

7.47 Where volumes are lower, lay-bys are equipped with a fixed LSWIM. The fixed LSWIM can also be replaced with a portable LSWIM where only random weighing of vehicles is anticipated.

7.48 **Portable weighing equipment:** Where satellite stations are not warranted, portable dynamic scales are used for screening purposes. These portable dynamic scales can be set-up next to any road where there is a suitable surface and an area to pull off and weigh trucks. These scales cannot be used for law enforcement purposes, but are sufficiently accurate to identify vehicles that are probably overloaded with a high degree of confidence. Due to the fairly high accuracy of the portable dynamic scales, screening can take place at considerable distances from the weighbridge, as the chance of diverting vehicles that are legally loaded to the weighbridge is slim. These mobile weighbridges are considerably cheaper than

static scales, are relatively light (around 110 kg), can be set up very rapidly and measure individual wheels, axles, axle units and vehicle/combination mass. An example of the Vehicle Load Monitor weigh-in-motion scale is shown in the photograph below.



Vehicle Load Monitor (VLM) weigh-in-motion

Weighbridge location

7.49 **Regional corridors:** By far the largest volume of intra-regional commercial traffic takes place on the main corridors of the region. The RECs in the ESA region have all embraced the corridor approach for more effectively implementing a number of transport facilitation measures, including overload control. In order to apply common procedures along corridors traversing several

states, it will be necessary to harmonize the legal, regulatory and administrative procedures pertaining to overload control so as to facilitate efficient intra-regional transport operations.

7.50 In support of the corridor approach, the ESA region should consider embarking on a coordinated overloading control program to construct a regional network of standardized weighbridge installation/traffic management centers (TMCs) which will not only provide overload control services, but also traffic management services. The number, location and category of TMCs would depend on the following:

- Ports of entry (Beira, Dar es Salaam, Mombasa, Maputo and Walvis Bay)
- Commercial centers (such as Nairobi, Lusaka and Harare)
- Development corridors (such as the Maputo, Northern and Trans-Kalahari corridors)
- Main freight routes (such as between Harare and Johannesburg)
- Traffic volumes
- Availability (or not) of escape routes

7.51 It is important that all key stakeholders, road authorities, law enforcement authorities, transporters and freight forwarders, are involved in determining the most suitable location and layout of each TMC. There are three different categories of TMCs that can be considered, depending on traffic volumes:

Category A: A full 24 hour TMC service with direct services in the form of overload control and auxiliary services in terms of traffic data collection for a variety of planning and monitoring purposes including development of transport indicators. An example of a TMC is shown in the photograph below.

Category B: A Category B centre will provide basically the same services as category A TMC but not on a 24 hour basis. It can be viewed as a scaled-down version of a Category A TMC.



The Heidelberg Traffic Management Centre in South Africa

Category C: The Category C services would include screening of heavy vehicles and comprehensive traffic observations. These services would not normally be rendered at a fixed centre, but on a mobile/roving basis, and are essentially complementary to the Category A and B TMC services.

7.52 **National routes.** A country's underlying philosophy regarding overload control will influence the location of weighbridges. If the philosophy is to totally eradicate overloading control it will be futile and too costly. On the other hand, if the philosophy is to conduct ad-hoc overload control on a shoestring budget, it will be equally futile because the freight industry is well equipped to circumnavigate any half-hearted approach. Our proposal is that the approach to be adopted must be based on the Pareto Principle or "80:20 rule", wherein 80 percent of overloading can be effectively controlled by focusing effort at 20 percent of the locations. It has been well proven that the cost per heavy vehicle increases significantly

the smaller the facility and if the facility is only operated either on an ad-hoc basis or for limited hours per day. The most cost effective weighbridge facility has proved to be a facility on a very busy road, with automated systems and operated on a 24/7 basis.

7.53 The main criterion with regard to location selection must thus be heavy vehicle traffic. Therefore, if a national strategy is adopted as proposed, *the main freight corridors have to be addressed as a first tier of implementation* as discussed above. A proper study is imperative to determine heavy vehicle movements and numbers.

7.54 The law of diminishing returns is very important to acknowledge in this regard (i.e. for every weighbridge added after a certain number, every additional investment has a smaller return until the return on that investment does not warrant any further investment.). The numbers and locations need to be optimized on a national level and therefore a national strategy is necessary. It must be noted that the total cost of a weighbridge should include capital expenditure, maintenance and operations expenditure over the lifetime of the facility.

7.55 The provision of a network of TMCs in the ESA region would be a costly undertaking. However, various financing mechanisms including a combination of government funding, user charges and public-private-partnerships can be considered as discussed from paragraph 7.84 onwards.

Weighbridge specification and procurement

7.56 There is generally a lack of consistency with regard to the technical specifications of weighbridges and weighbridge facilities in the region. This has mostly come about as a result of a fragmented approach driven by weighbridge suppliers wanting to sell their equipment. Many of these suppliers are not established in the region and have to support their equipment from Europe at huge cost and long downtimes. Local support of weighbridge systems is imperative. There are also instances where certain first world suppliers have dumped old technology weighbridges in Africa and providing no support. Due to a lack of investment and maintenance over an extended period there is a huge need for refurbishment or replacement of equipment.

7.57 There is also insufficient attention given to the selection of the types of weighbridge available for use in the ESA region. Many weighbridges cannot cor-

rectly weigh axle units – the basis upon which the SADC recommended overload control regime is founded. Weighbridges are either too small – they can only weigh one or two axles at a time – or they have single decks of dimensions such that weighing axle units separately is impossible. In many places weighbridges are used that do not match the traffic demand – they might be either too small or too large. The correct application to enable optimum performance is not always obvious and expert technical advice should be sought.

7.58 The use of dynamic weighbridges is also widely misunderstood. The term “dynamic weighbridges” refer to High Speed Weigh in Motion (HSWIM), Slow Speed Weigh in Motion (SSWIM) and Mobile Weighing Pads. This equipment can only – under current legislation – be used for screening and or remote detection of possible overloaded heavy vehicles and not for overload control law enforcement. Heavy vehicles still need to be referred to weighbridges with fixed scales for static weighing. The use of WIMs to assist with screening heavy vehicles in highly trafficked areas is very useful and becomes imperative in areas of very high traffic. The use of mobile weighing pads to patrol lesser travelled roads that could be used to circumvent a weighbridge facility has proved to be very effective, however for enforcement purposes a heavy vehicle still needs to be sent to a fixed scale at the weighbridge facility for static weighing.

7.59 There have been attempts to verify SSWIM equipment to legalize them for law enforcement, but the process is fraught with difficulties and it is not foreseen that they will be legalized soon.

7.60 There is furthermore a need to use different types of weighbridge equipment in different geographical locations e.g. in an area located far away from major towns or cities and that does not have stable and consistent electrical power supply, a weighbridge that can work both mechanically and electronically is more useful. More complex systems, requiring specialized support and maintenance should, not be used in areas where they cannot be supported or where there are better suited types of equipment for the area.

7.61 There is also a case to be made for standardization of equipment, allowing economies of scale to come into play. This aspect must always be balanced with the advantages of competition in the market. Again, if a national strategy is adopted, both economies of scale and good competition could be benefited from.

Weighing procedures

7.62 The status quo with regard to weighing procedures varies greatly across the region and even from weighbridge to weighbridge within countries. Weighing procedures flow from legislative requirements and the interpretation thereof. When the SADC recommendations are implemented on a regional basis and individual countries adopt national strategies aligned to the regional recommendations, weighing procedures will, for the most part, align themselves.

7.63 Obviously weighing procedures will vary from facility to facility due to the peculiarities of a particular weighbridge layout and the equipment used, but standardization with regard to the interpretation of legislation and its application needs to be achieved. It is necessary for a haulier to have comfort that if he is found to be legally loaded at one weighbridge he will also be legally loaded at all other weighbridges he might encounter along his route provided his load stays constant. This is unfortunately not the case currently and leads to much acrimony between transporters and the weighing authorities. Reasons for differences in recorded loads between weighing stations are often not fully appreciated and include:

- Hysteresis in the vehicle suspension (less evident in air than it is in steel suspensions)
- Shifts of cargo, or of its center of gravity, between successive axle-load weighings
- Changing of repose of axles in their bearings
- Spring flexure
- Clutch engagement
- Brake pressure
- Tyre compression
- Taking on additional load in between weighing (example filling of long-distance fuel tanks or additional cargo)

7.64 In view of the above, there is a case to be made for a dedicated effort to achieve alignment of interpretation of legislation and entrench it in standardized procedures. This has been achieved with specific individual departments but is not yet the norm. It is recommended that regional forums be established to facilitate this standardization.

Maintenance and verification

7.65 As mentioned earlier the Achilles heel of overload control is a lack of maintenance of weighbridge facilities. Maintenance has also been limited to repair work whereas preventative maintenance carried out routinely provides the greatest benefit in the long run. The latter aspect of maintenance is mostly overlooked with dire results.

7.66 Traditional approaches using departmental resources for maintenance of weighbridge facilities have generally failed. This is mostly due to a lack of understanding by the transportation department of the technical specialization required to properly maintain weighbridge facilities. As a result of the lack of understanding there is usually inadequate budgetary provision for maintenance resulting in breakdowns and costly repairs. This is even truer for more technically advanced facilities than for simpler systems.

7.67 It is imperative that maintenance of weighbridge facilities be planned by competent people and managed accordingly. It must be noted that weighbridge facilities do not only consist of a weighbridge or scale – there is usually a significant amount of supporting systems and equipment and buildings and roads that also need to be maintained.

7.68 Economies of scale again feature in this aspect. It is good practice to standardize equipment as well as maintenance procedures. If a number of weighbridge facilities are under the responsibility of one party a lot of efficiency could be gained and costs saved.

7.69 The procurement of term maintenance contracts with specialist suppliers based on performance measurement is a well established and successful feature of many industries. It has however not been widely implemented in the overload control environment. To implement such contracts requires expert technical and management support which the department should source from consultants.

7.70 Verification requirements are a function of legislation. The verification of weighbridges is usually done by the weighbridge suppliers themselves and should form part of the above mentioned maintenance term contracts.

Data capture and management

7.71 The capture of weighing data and the reporting thereof is an important part of the management of heavy vehicle overload control. With the increased computerization of weighbridge weighing, it is a relatively simple task to store this data on disk for subsequent analysis. At the end of each month, all the weighing data can be sent to the head office via a modem, where the data from all weighbridges are consolidated and reports generated using a Vehicle Overloading Management System.

7.72 Various statistics can be presented in monthly and annual reports, including number of vehicles weighed, overloaded and charged per weighbridge, maximum and average overloads for various regulations (e.g. permissible maximum combination mass, single axles, tandems and tridem axle units), operator statistics (the so-called “top offenders”, vehicle type statistics, commodity statistics and foreign operator statistics.

7.73 Figure 7.2 shows a typical graph from a weighbridge report which shows the historical distribution of overloaded vehicles.

7.74 In summary, the most important issues with regard to maintenance and verification are:

- Proper maintenance planning coupled with budgeting
- Routine preventative maintenance according to procedures and measured against performance standards
- Specialist term contracts with suppliers
- Maintenance management by technically competent persons

7.75 Without the above in place, maintenance will always stay the weak link in the overload control chain.

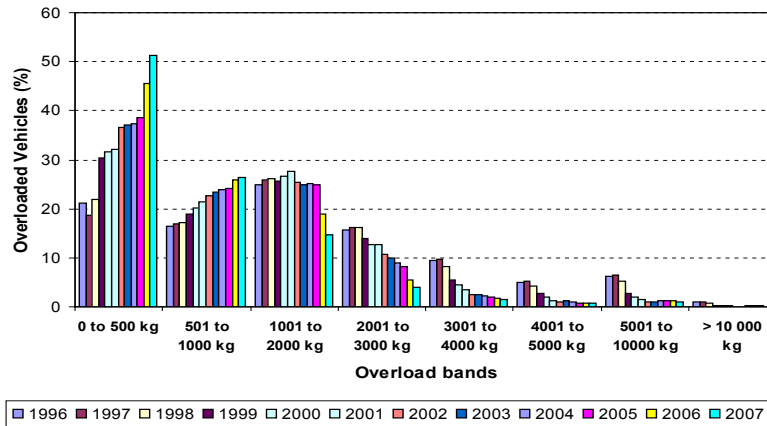

Figure 7.2 - Distribution of vehicle overloads (percentage): 1996 to 2006
(Ref. Kwazulu Natal Annual Overload Control Weighbridge Report: 2006)

MANAGEMENT ASPECTS

Levels of management

7.76 Effective management of weighbridge facilities is crucially important to the successful control of overloading in any country. Such management normally takes place at three levels.

7.77 **Overall management:** At this highest management level, the designated organization would typically be responsible for policy formulation and direction and the resources required for attaining the Government’s goals in the roads sector as regard overload control. This responsibility could lie with the following organizations:

- The ministry responsible for transport, or
- An “arms-length” autonomous or semi-autonomous Roads Agency which is typically responsible for strategic management and planning of the development, maintenance and rehabilitation of the national road network.

7.78 In the new institutional arrangements for the roads sector followed by most ESA countries, the ministry responsible for transport remains best placed for

providing policy formulation and direction. Under the direction of the ministry responsible for transport, the Roads Agency should then be responsible for policy delivery as regards strategic management of the technical aspects of overload control as described below.

7.79 **Strategic management:** The various strategic aspects of management would typically involve:

- Country-wide program planning
- Budgeting
- Resource allocation
- Target setting and monitoring
- General reporting on country-wide operations

For the reasons stated above, the Roads Agency is best placed to assume responsibility for all the above aspects of overload control.

7.80 **Operational management:** Involves day-to-day management of weighbridge operations such as:

- Planning and resource allocation
- Monitoring and reporting at local level
- Maintenance and verification of weighbridges
- Management of personnel
- Weighbridge operations

7.81 Various options are available for undertaking the operational management of weighbridge facilities including:

- **In-house operations:** In this option, the road agency takes full responsibility for the operational management of weighbridge facilities. However, historically, this arrangement for a variety of reasons, has generally not been very effective or efficient. Moreover, many of the weighbridge facility operations are not core functions of a Roads Agency and, in principle, should be contracted out to the private sector either as a commercialized or privatized operation.
- **Private sector operations:** In this option, the private sector may be appointed by the Roads Agency to carry out some or all of the operational management responsibilities listed above – in essence, a public-private partnership (PPP). Various PPP arrangements may be considered, each

with their advantages and disadvantages, as presented in Table 7.2, together with the in-house option.

7.82 As indicated in Table 7.2, different levels of success can be achieved with different levels of private sector involvement. What should however be noted is that as with any business venture if too much risk is transferred to the private sector, a large premium will be payable by the government.

7.83 It is also important to note that the above table is very generic in nature and holds true in general, there is however still the requirement that each privatization endeavor be planned carefully and optimized within the conditions that it will function. We propose a policy direction approach as opposed to blanket implementation enforcement. There is however no question as to the benefits that can be derived from privatization provided it is well specified and well managed. We wish to caution against service agreements that reward contractors for providing people. This approach leads to a lot of money being paid for no performance. The implementation of performance measures in this regard is propagated but must be well understood and managed. The performance measured approach is well in line with world trends with regard to management, maintenance and operations of infrastructure and has proved immensely successful and sustainable.

Model 1: No private sector involvement	
<i>Ownership of infrastructure</i>	Transport Department
<i>Maintenance responsibility</i>	Transport Department
<i>Operations responsibility</i>	Police or traffic police
<i>Enforcement responsibility</i>	Police or traffic police
<i>Legislative base</i>	National Roads Acts/regulations or similar: overloading as a criminal offence
<i>Bottlenecks/challenges</i>	<ul style="list-style-type: none"> • Split between Owner of infrastructure and law enforcement body. • Transport department has no authority over police • Transport department personnel cannot “direct” vehicles • Overloading seen as a minor offence by police and enforcement is given a low priority • Split between maintenance and operations responsibility leads to poor preventative maintenance and frequent downtime • Transport department does not have the technical competency to maintain weighbridge systems • Bribery rife

Model 2: No private sector involvement	
<i>Ownership of infrastructure</i>	Transport Department
<i>Maintenance responsibility</i>	Transport Department
<i>Operations responsibility</i>	Transport Department
<i>Enforcement responsibility</i>	Police or traffic police
<i>Legislative base</i>	National Roads Acts/regulations or similar: overloading as a criminal offence
<i>Bottlenecks/challenges</i>	<ul style="list-style-type: none"> • Split between Owner of infrastructure and law enforcement body. • Transport department has no authority over police • Roads department personnel cannot “direct” vehicles • Overloading seen as a minor offence by police and enforcement is given a low priority • Jurisdictional squabbles with regard to who is in charge of weighbridge • Transport department does not have the technical competency to maintain weighbridge systems • Bribery better with DoT on site

Model 3: No private sector involvement

<i>Ownership of infrastructure</i>	Transport Department
<i>Maintenance responsibility</i>	Works Department
<i>Operations responsibility</i>	Transport Department
<i>Enforcement responsibility</i>	Police or traffic police
<i>Legislative base</i>	National Roads Acts/regulations or similar: overloading as a criminal offence
<i>Bottlenecks/challenges</i>	<ul style="list-style-type: none"> • All of the above • Weighbridge low on priority of works department leading to poor maintenance and excessive downtime • Works department does not have technical competence to maintain weighbridge system

Model 4: Low private sector involvement

<i>Ownership of infrastructure</i>	Transport Department
<i>Maintenance responsibility</i>	Privatized
<i>Operations responsibility</i>	Transport Department
<i>Enforcement responsibility</i>	Police or traffic police
<i>Legislative base</i>	National Roads Acts/regulations or similar: overloading as a criminal offence
<i>Bottlenecks/challenges</i>	<ul style="list-style-type: none"> • Works better with regard to maintenance resulting in less downtime • Same problems as above with regard to jurisdiction and priorities leading to poorly motivated enforcement

Model 5: Medium private sector involvement

<i>Ownership of infrastructure</i>	Transport Department
<i>Maintenance responsibility</i>	Privatized
<i>Operations responsibility</i>	Privatized
<i>Enforcement responsibility</i>	Police or traffic police
<i>Legislative base</i>	National Roads Acts/regulations or similar: overloading as a criminal offence
<i>Bottlenecks/challenges</i>	<ul style="list-style-type: none"> • Works better with regard to maintenance and operations • Private sector not empowered to "direct" vehicles resulting in operational efficiencies reliant on police • Bribery much less

Model 6: Optimal private sector involvement	
<i>Ownership of infrastructure</i>	Transport Department
<i>Maintenance responsibility</i>	Privatized
<i>Operations responsibility</i>	Privatized
<i>Enforcement responsibility</i>	Privatized
<i>Legislative base</i>	Overloading decriminalized – enforcement of administrative charge
<i>Bottlenecks/challenges</i>	<ul style="list-style-type: none"> • Advantage: best possible set-up • Disadvantage – direct cost more

Model 7: Maximum private sector involvement	
<i>Ownership of infrastructure</i>	Privatized
<i>Maintenance responsibility</i>	Privatized
<i>Operations responsibility</i>	Privatized
<i>Enforcement responsibility</i>	Self regulation
<i>Legislative base</i>	National Roads Acts/regulations or similar: overloading as a criminal offence
<i>Bottlenecks/challenges</i>	<ul style="list-style-type: none"> • Has to be enough incentive to sustain • Only works with larger and well established portion of freight industry

FINANCING ASPECTS

Introduction

7.84 There is generally a lack of understanding of the level of investment required to implement and sustain effective, comprehensive and long term overload control. Thus, before considering possible funding scenarios one has to address a major myth with regard to overload control. Overload control cannot normally be self sustainable based on income from fines or fees. It is imperative that road authorities and funding agencies appreciate this important point.

7.85 With the above in mind it becomes clear that a low budget approach to protecting a strategic resource such as a country's road infrastructure will have

limited effect and it has been proven in the region that it is mostly not worth the investment. The reason for this is the criminal element involved that will continuously look for loopholes in the system and a low budget approach would have many loopholes. The opposite is also true as the law of diminishing returns also applies in the case of overload control. To attempt to completely eradicate overloading through an overload control regime that plugs every escape route and weighs every vehicle is virtually impossible and would be ridiculously costly.

7.86 When financing mechanisms are considered it must be noted that the implementing authority or body should be correctly chosen. For example, if it is agreed to adopt a national approach in line with regional initiatives it would be better to address overload control on a national level based on a coherent strategy. This will consequently lead to better economies of scale and be more sustainable. Fragmentation, such as when a national Department of Transport, the provincial Department of Transport, the local authorities, the cross border agencies and the port authorities all operate weighbridges and all involved in enforcement activities, should be avoided. These different authorities could have weighbridges for other reasons such as checking customs duties on loads or licensing etc. This not only leads to inconsistency in the approach but also results in duplicative effort and inefficiencies in overload control that are best avoided.

7.87 A further difficulty arises when funding for the overload control effort is fragmented at the operational level e.g. the maintenance is funded by the works department, operations by the roads department and enforcement by the police or traffic police department.

Financing models available

7.88 A number of financing models are available for the financing of weighbridge infrastructure, management and operations. These include:

- In-house
- Concessioning
- Dedicated road fund
- Public-private partnership
- Funding agency
- Private

7.89 The different financing models listed above all offer advantages and disadvantages which are summarized in Table 7.3.

Comments and recommendations

7.90 Considering the challenges the region faces of which funding is not the least, this issue is probably one of the make or break aspects to be dealt with. As with the funding of roads infrastructure the approach to the funding of overload control should be multifaceted. Certain countries and certain roads could be handled differently than others. It is nevertheless imperative that the whole effort be based on an integrated strategy.

7.91 It is our view that the management, operations and maintenance of weighbridges be privatized as part of a national strategy. To enable this, a national strategy has to be developed addressing inter alia the optimum location of weighbridges and the type of equipment to be applied.

7.92 With concessioned roads, it is proposed that overload control be part of the responsibility of the concessionaire and be included with the financial model of the concession. For non-concessioned major roads and part of the abovementioned national strategy, it is proposed that the funds for capital expenditure (Capex) for construction and or refurbishment of overload control facilities be procured either from the donor community (for the poorer nations) or from the national transport department's budget. A road fund could greatly assist with providing Capex funds.

7.93 Alternatively, Capex funds can be procured from the private sector provided that the transport department is willing to fund the development of the project to the point where bank risks are sufficiently addressed. The transport department would also have to have the mandate and the willingness to guarantee the pay back of the Capex and fund the operational expenditure (Opex) for a period. This type of agreement would typically include a period of five to seven years of operations also addressing the issue of sustainability at least for the short term.

7.94 The sustainability of overload control is largely dependent on committed funds for Opex. This is usually the greatest challenge as it is usually underestimated leading to poor maintenance and eventual deterioration and partial or full close down of operations. As mentioned above, as part of a concession, this aspect is fully addressed. However, outside of concessions, neither the donor agencies nor transport departments have in general shown an understanding of the level of funding required to ensure sustainability. To ensure sustainability it is proposed that the management, operations and maintenance of overload control facilities be

privatized based on a national strategy to achieve long term committed funds, consistency of effort and economy of scale.

Conclusions

7.95 Experience from a number of countries has shown that the conventional approach of undertaking ad hoc construction of overload control facilities by transport departments out of their own budgets and the operation of weighbridges by traffic police out of their own budget is not the good practice and is generally not sustainable within the region. In this approach, weighbridge maintenance is addressed when funds are available which leads to long breakdown periods and eventually shutdowns. Instead, consideration should be given to involving the private sector in the financing, management and operations of weighbridge infrastructure in the various ways described above.

Table 7.3 Advantages and disadvantages of different financing models

Financing Model 1: Departmental force account	
<i>Application</i>	All aspects: CAPEX and OPEX
<i>Source of funding</i>	National budget
<i>Comments</i>	This is the most common model found in the region. Limitations are: <ul style="list-style-type: none"> • Usually lacking due to low priority of overload control as a function of the Department of Transport • Not based on an integrated national strategy
Financing Model 2: Concessioning	
<i>Application</i>	All aspects: CAPEX and OPEX
<i>Source of funding</i>	Private sector
<i>Comments</i>	This has not been successfully been implemented. Limitations are: <ul style="list-style-type: none"> • Can only be part of a larger road concession as it will require a cross subsidy from the road concession • Can work if included with the concession from the beginning

Financing Model 3: Dedicated road fund	
<i>Application</i>	All aspects: CAPEX and OPEX
<i>Source of funding</i>	Road user charges
<i>Comments</i>	This has been proposed and partially implemented in Namibia. Limitations are: <ul style="list-style-type: none"> • The establishment and maintenance of a road fund stretches beyond the boundaries of overload control
Financing Model 4: Public-Private Partnership	
<i>Application</i>	CAPEX from private funds OPEX from Department account
<i>Source of funding</i>	Private banks/Departmental budget
<i>Comments</i>	This has been investigated with both banks and departments showing interests. Limitations are: <ul style="list-style-type: none"> • Development funds – banks taking low risk approach – will not fund concept development without guarantees, etc. • Department's legal mandate to enter into a PPP contract to pay back CAPEX or PPP contract period
Financing Model 5: Funding agency	
<i>Application</i>	CAPEX from donor OPEX from Department account
<i>Source of funding</i>	Donor countries
<i>Comments</i>	Usually part of a road program. Limitations are: <ul style="list-style-type: none"> • Funding agencies are willing to fund CAPEX but not OPEX • Host country poor and not able to sustainably fund OPEX
Financing Model 6: Funding agency	
<i>Application</i>	All aspects
<i>Source of funding</i>	Private
<i>Comments</i>	Application mostly within a single organization as part of self regulations. Limitations are: <ul style="list-style-type: none"> • Limited to large corporations – not available to individual hauliers • Not directly used for enforcement

PENALTIES

Introduction

7.96 Vehicle overload control, the level of penalties, and the judicial/administrative mechanisms to deal with the problem, have received considerable attention during the past three decades throughout the world. A primary factor has been the realization that an increase in axle load causes road damage to increase at an exponential rate, commonly taken as a fourth power effect.

7.97 The problems of vehicle overloading are exacerbated in the ESA region compared with more developed countries by numerous factors, chief amongst which are the enforcement and penalty aspects.

7.98 The fines imposed for overloading, both by traffic officers for admission of guilt and by magistrates in a court of law remain, in most cases, unrealistically low compared with the damage done by the vehicle on the road and the higher profit made by the hauler in transporting a heavier load. Fines do not have a significant effect on discouraging overloading and the income derived from these fines is insignificant compared to the road damage. Generally, the income from fines is paid into a "central account" and is not directly available for road maintenance purposes.

Fees for overloading

7.99 There is a need for the introduction of some form of economically based fees to recover costs of accelerated pavement damage from the operators of overloaded vehicles. Such a fee should include for the following:

- Pavement damage
- Bridge damage
- The extent of overload control
- Travel distance
- Punitive effect

7.100 Fee Schedules for Overloading were prepared by SATCC in 1993 with the various assumptions for calculating the fee schedule being based on the 1993 SADC Axle Load Study for Southern Africa (TOI report 180/1993). The underlying

ing rationale within the proposed fee structure is that the fees levied will clearly outweigh any cost benefits to the operator to overload for commercial gain.

7.101 The SATCC fee schedules for overloading has provided the basis for charging for overloading by a number of countries in the ESA region. However, these schedules need to be updated based on the information contained in the study carried out for SADC on Implementation of Harmonized Road User Charges System in the SADC. June 2007.

HUMAN RESOURCES AND TRAINING

Introduction

7.102 Adequate and acceptable training should be provided to traffic officers (and private staff if applicable) at weighbridges and Traffic Control Centers (TCCs), so that they are able to perform optimally. This is to ensure that the applicable regulations are applied correctly and that policies and procedures are consistent at all weighbridges within a country. Furthermore, training in the SADC Region should be coordinated as far as possible in order to achieve uniformity in overload control policies and procedures even though the mass regulations in the SADC Member States are currently not uniform.

Aspects to be addressed during training

7.103 Training of staff involved in overload control should cover the following aspects:

- The terminology used in overloads control and overload control legislation. This is to assist the trainees to understand and interpret the legislation.
- The power of traffic officers as it relates to overload control.
- Training relating to the court process. Trainees should be informed on what to do before and during a court appearance. It should also provide general information on the prosecution of road traffic cases and giving of evidence. Further topics to be included are the handling of the property of the accused after he/she has been arrested and the arrest procedure.

- Training on the regulations relating to overload control. Trainees should fully understand the various regulations and how they fit together. Trainees should be able to apply the regulations and perform the various calculations without the aid of a computer program.
- Training on the screening of vehicles. This should include visual screening and the use of screening devices.
- Training on the information plates that should be displayed on vehicles. The trainees must know what information is required on these plates and must be able to interpret the information and apply it correctly during the overload control process.
- Training on any presumptions applicable to overloading prosecutions.
- Training on a structured uniform procedure for overload control. This should include the authorities that are part of the overload control process their duties. Procedural guidelines, which have to be followed by a law enforcement officer, should be covered. These procedures include screening, referring the vehicle to a weighbridge and the determination of the permissible maximum mass of a vehicle. This section further should include procedures for charging, seizure and arrest and parking and adjustment of loads. Methods for dealing with moving loads, abnormal loads and documentation should also be provided.
- Training on the application of the tolerance margins.
- Training in the use of the equipment utilized in the overload control process, such as the static scale, tape measures, portable scales or screeners and the requirements relating to the regular verification of the equipment.
- Training in the use of software packages. The trainees should be able to use the software during the overload control process and must be able to interpret the results and output obtained from the programs.
- Training in the reasons why it is important to do overload control. This should include aspects such as the damage caused by overloaded vehicles, the road safety problems caused by overloaded vehicles and the unfair competition that results from inadequate overload control.

Typical training module

7.104 An example of one of a number of training modules on overload control is presented in Table 7.4. Similar modules should be developed on the various aspects of overload control indicated above.

Table 7.4 – Contents of typical training module

Transport environment	
<i>Target audience</i>	All staff
<i>Objective</i>	To impart a basic understanding of the transport environment and the reasons why overload control is important
<i>Content</i>	<ul style="list-style-type: none"> • Introduction • The importance of the transport sector for the economy of a country • The importance of a national road network for economic and social development • Basic principles of road design • What is overloading • The effect of overloaded vehicles on the road infrastructure, including bridges • The effect of overloaded vehicles in terms of road safety • Why operators overload and the profits made

PUBLIC SUPPORT AND COOPERATION

Public awareness campaign

7.105 There is a general lack of awareness among the public at large and the heavy vehicle operator's fraternity in particular about the need for overload control and the negative effects of overloading on the national or regional economy. In order to engender an awareness of the importance of overload control and to elicit support from all stakeholders, it is necessary to mount and sustain an appropriate awareness campaign. The focus of such a campaign would be to ensure that these users understand the consequences of overloading on the road infrastructure understand the various regulations and are in a position to implement them, and also understand the legal consequences of overloading.

Target audience

7.106 The target audience for the awareness campaign should include the following stakeholders:

- Local courts
- Public prosecutors
- Transporters
- Consigners and consignees
- Drivers
- Weighbridge staff



Examples of billboards used to create awareness of overloading

Means of dissemination

7.107 A variety of means can be used to support the awareness campaign, including:

- Awareness pamphlets and posters
- Installation of billboards at critical locations on the road network (see photo below)
- Periodic seminars and press conferences, and
- “Naming and shaming” habitual offenders

SUMMARY

7.108 This section has dealt with a wide range of technical options for a number of key issues that affect overload control operations in the ESA region. In particular, the critical importance and urgency of harmonizing vehicle load limits has

been stressed and various enforcement aspects of the overload control process highlighted. Choosing the right kind of weighbridge infrastructure in relation to the prevailing circumstances has also been emphasized. The management and financing aspects of overload control have also been addressed and the desirable role of the private sector in these aspects of overload control has been highlighted. The importance of charging economically based fees has also been highlighted as well as the critical importance of harmonized training at regional level and the support of the public for overload control through an appropriately formulated publicity campaign.

8. ANNEX: SUMMARY OF MEETINGS AND WORKSHOPS HELD IN THE REGION FROM 1985 TO 2007

1. SATCC: Control of Overloading in Southern Africa. Nov. 1985

8.1 (a) Background

This report is based on a special survey of the overload control situation in the SADC region that was carried out in 1985 by the Institute of Transport Economics (TOI) on behalf of SATCC. The initial findings of the survey were presented to the Working Group on Road Traffic and Transport in Gaborone in 1985. At a subsequent meeting held in Blantyre in November 1985, the report was discussed and its recommendations adopted by the Working Group as a basis for harmonizing and improving overload control in the SADC region.

8.2 (b) Recommendations

The main recommendations of the report were as follows:

1) Laws and regulations

The member countries should review the laws and regulations to ensure the following:

- the control staff to be given the power to stop and control a vehicle
- they must be able to detain a vehicle until the excess load is removed/reloaded and any fine/fee has been paid
- the fines/fees to be progressive with respect to the amount of overload to reflect the relation between the amount of overload and the damage to the roads

- the fines/fees to be determined on the spot to avoid unnecessary delay, with opportunity to appeal the decision within a certain period of time.

The issue of harmonizing the axle load limits within the region is very important to follow up, in order to make border crossings easier, to avoid misunderstandings for international haulers, and to make regional transport more efficient.

A standard regulation proposal on the above mentioned points is included in the report on “Road Traffic Laws and Regulations in Southern Africa” as a guide to the member countries in adjusting the regulations of each country. This may encourage harmonization not only in respect of the axle load limits but also of the axle load regulations in general.

2) Enforcement

Enforcement of the regulations is a necessary final step in the overload control process. The enforcement procedures should be made as simple as possible, enabling the drivers to continue their journey as soon as possible after the load has been brought down to legal limits, and the fine is settled.

Consideration should be given to simplifying the enforcement routines by replacing the fines with a fee which can be charged administratively for overload. This does not have to exclude penal sanctions or appeals.

It is advisable that the weighbridge team at least consist of one policeman and one motor vehicle examiner.

3) Training of personnel

The training of personnel should be given considerable attention.

The most economical long term solution might be a regional training centre in one of the countries.

One solution might be to develop the vehicle inspector training centre in Harare into a regional centre, training also overload control officers from the different countries.

The overload control personnel should be able to also check the technical condition of the vehicles. For this reason, the overload control training might be seen as an extension of the motor vehicle control training.

4) Information

Information to transporters and drivers about the overload regulation, the problem of overloading and some advice about load estimation should be available. This could be made in the form of a brochure and should be available at custom posts, weighbridge sites and government offices.

Weighbridges in urban and industrial areas should be made available to transporters who voluntarily want to check loads to get experience as to, the legal loading of a vehicle.

5) Equipment

Fixed weighbridges should be available at strategic points on international roads within each country. These should be supplemented by mobile weighbridges to make a complete overload control system.

In each of the SADCC countries an inventory should be made of their weighbridge equipment, giving information about type and manufacturer, the installation year, state of maintenance, last date of calibration and calibration intervals.

This should be used to establish how many of the existing weighbridges has to be replaced in the near future, and the need for better calibration and service routines. A priority list of the need of new weighbridges, permanent and portable, to cover the trunk road network should also be made.

7) Management and control systems

The weighbridge report should be completed with two copies. One copy as a receipt to the driver. One copy and the original to the Roads Department (or the regional branch) archives for statistics and control.

Once a month, a list of all foreign vehicles charged with an overdue fine/fee should be sent to all border crossings as a means of stopping foreign vehicles from neglecting to pay an overload fine.

2. SATCC: Overload control and weighbridges – Review of present situation in the SADCC region, Nov. 1991

8.3 (a) Background

Following the survey of the overload control situation undertaken in 1985 by the Institute of Transport Economics (TOI) on behalf of the SATCC, updated information was collected from five countries (Botswana, Malawi, Namibia, Tanzania and Zimbabwe in October/November 1991. The report is based primarily on the information collected in those countries.

8.4 (b) Recommendations

The main recommendations of the report are as follows:

1. Introduction of a more effective system for overload control is urgently required in most member states. Such a system will not only include weighbridges but also better legal provisions, improved enforcement and an effective management and control system for the weighbridges.
2. The legal text in the SATCC Road Traffic Model Statute provides the general basis for overload control. It is, however, anticipated that new regulations may be required, and concrete proposals as to such regulations should be prepared taking into account the possible use of progressive and administratively charged fees.
3. The technical unit should draft harmonized regulations for the urgent consideration of the Working Group taking into account all relevant authorities in the member states including the ministries of justice.
4. The regional aspects of the weighbridge projects and the proposed traffic data acquisition project should be emphasized by the Technical Unit and project documentation prepared in this respect for presentation to donors.
5. The technical unit should consider convening a technical meeting to discuss and recommend on various legislative, enforcement and administrative aspects of more efficient systems of overload control. Such meet-

ing should be attended by the relevant authorities, e.g. Ministries of Justice, Ministries of Transport and Roads Department.

6. At a later stage, when the contents and mechanisms of a more efficient system for control of overloading has been agreed upon by SATCC, it should be considered to convene a technical donors conference aimed at securing financing of the weighbridge projects and possible the data acquisition project.

3. SATCC: Review of present situation and previous proposals, Feb. 1992

8.5 (a) Background

This report is a follow-up to the previous Working Paper of 7 November 1991 and was prepared as a background document for the consideration of the SATCC 5 Country Special Working Group on Overload Control. The report includes the proposals made previously in the report on Control of Overloading dated November 1985.

8.6 (b) Recommendations

The recommendations of the November 1985 report are repeated in the February 1992 report.

4. PTA: Institutional policies & measures for regional axle load control, July 1992

8.7 (a) Background

As a follow-up to a 1998 Study on the Harmonization of Road Tolls, Transit Charges, Axle Load and Vehicle Dimensions, the Preferential Trade Area (PTA) for Eastern and Southern Africa States embarked on a study to design a simple, efficient and self policing system of axle load control in order to clearly define the respective roles, responsibilities and liabilities of governments, transport operators and freight forwarders.

8.8 (b) Main conclusions and recommendations

(1) Effective regional axle load control requires regional instruments and common institutional and administrative practices. The provisions of Article 4 of sub-paragraph 2 (b) of Annex V to the treaty provide the legal basis for the code of conduct of PTA licensed hauliers. The same provisions provide exchange of information on between countries carriers who transgress the law and prohibition from being engaged in intra-PT A transit traffic operations.

(2) A simple and "self policing" system of axle load control at the regional level is one that makes it a condition in the PT A carriers license for the haulier to observe axle load limits of the transit country. At the operational level it shall be a mandatory requirement for the haulier to obtain a PTA axle load certificate prior to the commencement of a transit journey. No heavy goods vehicle shall be admitted into the territory of a transit country unless it is in possession of a certificate issued by a licensed authority.

(3) The meeting should consider the following recommendations:

(i) The observance by hauliers of Road Traffic Laws and regulations, including axle load limits is one of the conditions for the issuing of a PTA carriers license.

(ii) That governments should nominate institutions and/or companies to issue PTA Axle Load Certificates. For efficient administration, it is proposed that this function be carried out by the private sector, with the role of government departments confirmed to auditing the work done by the licensed companies.

(iii) The PTA Axle Load Certificate be issued to carriers that are in possession of a valid PTA carriers license at the time of loading or dispatch of the vehicle.

(iv) A loaded truck that has no valid PTA Axle loaded certificate shall not be allowed to engage in inter-state haulage of cargo.

(v) An operator whose truck is caught more than three times with loads exceeding axle load limits shall be banned for three years from engaging in inter-state transportation of goods.

(vi) Member State shall exchange information on hauliers who violate Axle Load Limits through the PTA Secretariat who shall prepare a schedule of such transgressors including hauliers that are banned.

(vii) for purposes of transparency, accountability and justice, a banned haulier has the right to produce evidence through the Secretariat to the Committee on Transport and Communications showing that such a ban was not justified. The Committee shall consider submissions by parties involved and give an advisory opinion.

5. SATCC: Axle load study for Southern Africa, May 1993

8.9 (a) Background

The SADC countries intend to harmonize legislation on road traffic, including weights and dimensions of heavy vehicles. The objective of the study was to estimate an optimum maximum load for the SADC region, based on typical conditions for the SADC trunk route network and representative costs of road maintenance and road traffic. The optimum maximum axle load is defined as the Axle load that, if permitted, will minimize the combined cost of road agencies (construction and maintenance costs) and road users (vehicle operating costs).

8.10 (b) Conclusions and recommendations

The study arrived at an optimum axle load for a single dual-wheel axle of approximately 13 tons. Allowing for possible inaccuracies in input data and modeling and for tolerance of weighing equipment, a legal maximum of 12 tons was recommended as a basis for harmonization of axle loads in the SADC region. As regards tandem and tridem axles, the study recommended limits of 18 tons and 24 tons respectively, while a GCM of 63 tons was recommended.

6. SATCC: Axle load & vehicle mass control – overloading fee schedules, Nov 1993

8.11 (a) Background

This report was prepared for the Final Meeting of the SATCC 5 Country Special Working Group on Overload Control, Dar es Salaam, 13-15 October, 1993. The report reviews the economic arguments for a progressive fee schedule, and the assumptions for calculation of the fee schedules. Detailed fee schedules are calculated for different axle combinations with different axle load limits (8.2, 10 and 13 tons for single axle dual wheel. Regulations of gross vehicle mass are also addressed. A fee schedule for overload with respect to GVM is also proposed.

8.12 (b) Recommendations

The report was prepared for the consideration of the SATCC 5 Country Special Working Group on Overload Control. It contains no specific recommendations but implies that the fee schedules be given serious consideration by the Working Group in producing their final report.

7. Five country working group on overload control, final report, Sept. 1993

8.13 (a) Background

Upon completion of the Axle Load Study for Southern Africa, a Five Country Special Working Group consisting of Botswana (Chair), Namibia, Malawi, Tanzania and Zimbabwe was set up with the objective of preparing specific recommendations on strategies for implementation of overload load control based on a review of previous recommendations not yet implemented in member states.

8.14 (b) Recommendations

Penalties

1. Introduce "Infringement" system instead of current "prosecution" system. This system is used by many of the developed countries, and has

greatly improved overload control and the collection of fees for overloading offences.

2. Fees for overloading should be revised steeply upwards to recover cost of pavement damage. Current fees for overloading, in addition to not being collected, are too low. The damage done to the road system increases as the 4th power of the load on the axle. The new fees would recover the cost of the damage, and also provide a disincentive to overload.
3. Amendments were proposed to the SA TCC Road Traffic Act Model Legislation to correct the difficulties with the interpretation of the Act, and to simplify the complex nature of the regulations.
4. Expedite harmonization of SA TCC adopted 13 tons axle load as long-term goal and 10 tons as short term goal. As pointed out in the axle load study, the benefit/cost ratio of introducing the higher axle loads is very high. Delay is costing the SADC region money.

Infringement rather than prosecution

Under the prosecution system the processing of the overload offenders in court could take months or years, and because of the heavy court work load, the cases were very often dismissed. The infringement system will treat most offences out of court (like speed or parking offences) and the "fees" will be dealt with by administrative rather than legal procedures. This will ease the burden of the court which is left to deal only with cases that are appealed because the correct procedures were not followed. This is a major shift in thinking for the SADC region.

The implementation of the infringement system requires changes in the SATCC Model Road Traffic Act. The recommended changes have been incorporated in the FCWG report as amendments to the Model Road Traffic Act.

Upward revision of fees for axle loads above the design specification

The FCWG report has calculated and has published tables giving the appropriate fee level for progressive levels of overloading. These fees include considerations of factors such as the pavement damage, probability of detecting an overload, distance travelled, and a punitive element for gross overloads. A typical fee would be \$117 for a one ton overload, \$1,160 for

a 5-ton overload (about 10 times the one ton overload) and \$4,785 for a 10-ton overload (40 times the fee for the one-ton overload).

Amendments proposed to the Model SATCC Road Traffic Act

The proposed legislation includes amendments that have to be introduced in the SATCC Road Traffic Act, and the SATCC Road Traffic (Vehicles) Regulations. A new set of regulations called the Road Traffic (Overload) Regulations are proposed for introduction. Important additions to the Act are that overload offences shall not be deemed a criminal act and shall not be prosecuted.

If a vehicle is found to be overloaded, the fee shall be paid by the owner of the vehicle, and the fee shall be paid to an authority designated by the Minister. Such an authority could be the Road Fund which several Member States already have, and are now being set up in the other Member States under the provisions of the Protocol.

Other recommendations of the FCWG

- SATCC Road Traffic Model Legislation is amended to overcome lack of legislative authority to effectively enforce axle-load control.
- A campaign of public awareness should be launched to highlight cost to economy of high axle loads.
- Attention should be devoted to controlling tyre pressures because of the severe stresses imposed in the upper layers of pavement.
- Citing of weighbridges should be coordinated in order to promote efficiency. For example, consideration should be given to combine weighbridges on each side of a border.
- Weighbridge equipment, training, and procedures should be standardized.

Note: The recommendations of the 5 Country Special Working Group were adopted by the SATCC Committee of Ministers in June 1994 and constitute the basis for regional harmonization.

8. SATCC: Proceedings: Vehicle Overload Control Workshop, Feb. 1998

8.15 (a) Background

The workshop was organized by SATCC and was held in Maputo from 24th – 26th February 1998. The main objectives of the workshop were:

- Review the current situation in regard to vehicle overloading practices throughout the region, and the initiatives which are being taken or are under consideration by Member State Governments and by the trucking industry.
- Establish the membership and working procedures of the Vehicle Overloading Control Working Group (VOCWG).
- Identify desirable elements of the MOU and establish the preferable institutional approach for correction of the overloading problem.

8.16 (b) Main recommendations

1. It is resolved that in order to correct the serious problem with overloading in most SADC states, the following measures are necessary:
 - establish a Vehicle Overloading Control Working Group (VOCWG)
 - the VOCWG will draft a Memorandum of Understanding for consideration by all member states
 - the MOU shall include the following issues
 - reduce or eliminate the prosecution procedures in enforcement
 - improve coordination of efforts nationally and regionally
 - overcome ignorance and lack of appreciation in Finance and other government Departments
 - eliminate the benefits in overloading to the operator
 - sensitize governments to give overloading the priority it deserves
 - improve supervision of control and enforcement

- introduce fees system at more realistic levels to be an effective deterrent and related to road damage
 - implement harmonized axle load limits
 - introduce effective reporting controls
2. To improve efficiency and effectiveness in Weighbridge management attend to the following:
 - lack of equipment, staff, motivation and supervision
 - eliminate bribery
 3. The Working Group should strongly support member states governments in addressing the problem of VOC but are restricted by lack of funding and limited resources. These measures include enhancing the initiatives currently planned but that are not fully effective because of lack of funding, lack of implementation of agreed initiatives at regional level and proposed by the FCWG
 4. The WG will address short -term actions that can be taken to quickly improve vehicle overloading control. These include:
 - improved supervision
 - setting up incentives for weighbridge staff
 - changing legislation from fines to fees
 - monitoring alternative/escape routes
 - application of enforcement
 - repair of existing equipment
 - training and education through various means for operators, enforcement officers, magistrates and prosecutors
 - involve private sector participation albeit cautiously, and to monitor current initiatives
 - establish an independent body such as a Road Board to monitor private sector operations explore funding possibilities from the private sector through arrangements such as BOTs.

5. It is resolved to introduce a new approach “a paradigm shift” is required to effectively control overloading because the traditional criminal approach with harsh penalties and dependence on the criminal court system is ineffective. This will be accomplished by the following measures:
- an axle load and gross vehicle mass limit is necessary in the new legislation
 - Continue with the tolerances which need further consideration
 - Overloaded vehicles must pay the fee or fine and redistribute and/or off-load onto another vehicle. Provision needed for hazardous substances and perishables
 - Decriminalization desirable- adopt fee basis
 - Regional adoption of all measures
 - Establish a regional database on overload control which facilitates identification of habitual offenders
 - introduce a system to penalize habitual offenders
 - Involve the trucking industry by education e.g. Level playing field, assuring
 - that the overload fees are dedicated to maintenance, equitable fee structure
 - setting up workshops, an involving the truckers through the road fund board.

8.17 (c) Summary

The most important new ideas that emerged from the meeting were:

1. the necessity to decriminalize overloading by treating the offence administratively, and outside the traditional but inefficient prosecution procedures;
2. to make the users of heavy vehicles pay fees for the axle-load and vehicle-weight related wear-and-tear and damage inflicted on the roads and bridges;

3. to ensure that the money collected from the road users is efficiently dedicated to road maintenance through the mechanism of the Road Fund and Road Fund Board, and
4. to speed-up the harmonization of the regionally accepted single-axle load limit of 13 tons.

9. SATCC: Enabling legal reform: Control of overloading, March 1999

8.18 (a) Background

This document contains two instruments to be annexed to the SADC protocol on Transport, Communications and Meteorology, namely:

- Model Legislative Provisions (MLP) on Management of Vehicle Loading, and
- A Memorandum of Understanding (MoU) on Vehicle Loading

8.19 (b) Main elements of the MLP on vehicle loading

The MLP on vehicle loading implement the relevant legal reform recommendations contained in the report of the SATCC 5 Country Special Working Group on Overload Control. In so doing, the MLP respond to:

- A high degree of lawlessness in respect of vehicle loading
- Ineffectiveness of the criminal justice system in effectively regulating overloading
- Institutional fragmentation, i.e. the lack of real institutional controls and financial links between road authorities and road damage
- Recognition of the need to move to a “decriminalized” regulatory approach

Figure 8.1 National institutional arrangements for ensuring participative approach to setting load limits and levels of fees

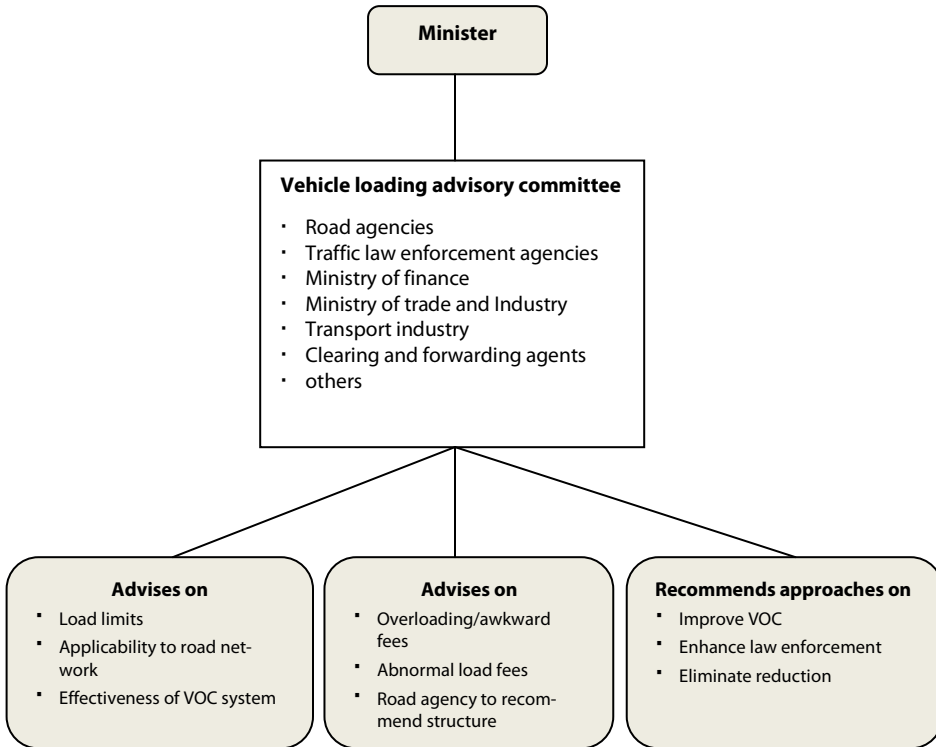

Regulatory approach

- Overloading prohibition (overloading results in liability or pay overloading fee)
- Mobility restriction applies:
 - Load to be off-loaded or redistributed to comply with limit
 - Fees to be paid or acceptable guarantee provided
- Liability to pay fee enforceable as a civil court order
- Points demerit system may be introduced providing for:
 - categorization of overloading according to severity
 - administrative sanctions to be imposed once point thresholds are exceeded

- reduction of points for "good behavior"
- Administrative sanctions (to apply in addition to liability to pay a fee):
 - temporary ban on road / route use
 - higher scale of fees
 - withdrawal of operating license
- Certain offences remain: failure to pay fee, damage to road, failure to present for weighing, failing to comply with direction of authorized officer

Setting of limits and fees: Participative approach

The national institutional arrangements for ensuring a participative approach to setting vehicle load limits and fees is illustrated in the figure above.

Vehicle loading: Management approach

- All vehicles must present for weighing (only exception: where a pre-journey weighing certificate can be produced issued by an accredited weighing station)
- Abnormal/awkward loads: Carrier must make pre-journey declaration and pay applicable fee
- Supplementary conditions may be imposed for abnormal/awkward loads, e.g. presentation for weighing, escorts, travel times, warning lights, etc.
- All fees to be transferred to road fund on a monthly basis or as prescribed.

Vehicle overloading: Network infrastructure and services

- Road authority to develop outsourcing strategy:
 - weighbridge strategic plan (existing and future network planning, procurement schedule, private investment options)
 - outsourcing plan (identification of functions, e.g. weighbridge operation, data management, fee collection, outsourcing options, etc.)

- Outsourcing to be undertaken by way of agency agreements providing for performance targets, audits, incentive payments, etc and compensation based on commercial principles
- Weighing station: May be operated by any person 'subject to accreditation requirements
- Road authority to develop standards for weighing stations
- Minister to appoint inspectorate of weighing station to conduct annual and random audits

8.20 (c) Main elements of the MLP on vehicle loading

The main elements of the MLP on vehicle loading may be summarized as below:

- The MoU commits member states to decriminalize overloading and to introduce a system of administrative controls based on harmonized load limits.
- Non-compliance is subjected to punitive financial sanctions, mobility restrictions, administrative sanctions and a point demerit system.
- Primary management responsibility is vested in roads authorities.
- Financial sanctions increase exponentially; higher damage attracts an even higher penalty.
- Commitment to implement voluntary compliance programs introduced.
- Commitment to private investment in and operation of weigh bridges and to joint operation of weighbridges situated in border areas.
- Establishment of a regional vehicle overloading control association.

10. Inaugural Meeting of Regional Overloading Control Association, Aug. 1999

8.21 (a) Background

In accordance with the Model Legislative Provisions on Vehicle Loading, an inaugural meeting of the Regional Vehicle Overloading Control Association (REVOCA) was held in Gaborone, Botswana on 10th August 1999. The main objective of the meeting was to agree on the modalities for adhering to the institutional arrangements as well as to consider the implementation of three pilot projects for involving the privates sector in the operation of weighbridges.

8.22 (b) Main outputs of meeting

1. Establishment of a vehicle loading advisory committee

The Implementation Process needs to be managed firmly with regular interaction with key stakeholders. In keeping with the inclusive approach adopted by the SADC MLP, it is recommended that a Vehicle Loading Advisory Committee (VELAC) be established to oversee and guide implementation. This body must have decision-making authority and should therefore be properly representative of stakeholders. One of the key functions of VLAC would be to sign off the various implementation tasks and, in so doing, obtain further policy guidance from the Ministry of Public Works and Housing if required.

Composition of VELAC

VELAC should be composed of representatives of key stakeholder organizations including those shown in Figure 3.1. As the body responsible for overload control, VELAC should be chaired by the national roads agency. The Steering Committee will be appointed by the roads agency after consultation with the Minister of Transport.

Working groups

VLAC may delegate specific tasks to working groups made up of persons with particular knowledge and experience. For purposes of implementation, there will be six working groups:

- Legislation and Regulations
- Infrastructure and Equipment
- Operations
- Institutional Structures
- Human Resources
- Public Awareness

Meeting frequency

The frequency of VLAC meetings will be decided by the chairperson. However, the committee should meet frequently enough for the Working Groups to refer back to but not so frequent that substantial work cannot be done between Steering Committee meetings.

Implementation success factors

The chairperson of VLAC must be dedicated to the implementation process. To ensure the success of the implementation process:

- A well constituted VLAC is paramount to a successful implementation, including a broad representation of public and private stakeholders to ensure that a range of views is heard
- Members of the Working Groups must be highly motivated, with a strong interest in the implementation of the vehicle overloading strategy
- VLAC should review the implementation schedule periodically
- The Working Groups need to ensure that the affected entities have the opportunity to provide input where appropriate

2. Development of a Regional System of Overload Control (RESOC)

The regional system of overload control should be:

- Integrated – i.e. equipment and procedures must be standardized or harmonized (one of the objectives of REVOCA)
- The private sector will be relied upon for most or all operations of RESOC. This will include design and operation of a quality control system to monitor effectiveness of the system components and for development or upgrading and subsequent installation of WIMS and mobile weighbridges
- The entrance into a regional MoU will open up regional and corridor contracting opportunities
- Need for central point of collection of regional information on vehicle loading which all member states can access. The initial depository could be at SATCC and, ultimately, with ASANRA as the secretariat
- Training in regard to vehicle overload control is important and must be determined by REVOCA with inputs from VELAC

3. Way forward

It was agreed at the meeting that:

- Delegates to call national meetings to discuss the formation of VELACs with a target date of 31st March 2000.
- National roads agencies are to take the lead in implementing the agreed regional strategy on overload control. VELACs to be attached to the national roads agencies as sub-committees.
- There should be a direct relationship between the national VELACs and regional REVOCA. REVOCA members should also include other stakeholders such as FESARTA.
- Three donor-supported pilot projects to assess the effectiveness of the private sector to operate weigh stations and control vehicle overloading should proceed as soon as possible (Botswana, Namibia and KwaZulu Natal).

11. Workshop on axle load limits and overload control, Nairobi, Sept. 1999

8.23 (a) Background

1. The workshop was convened by COMESA for member states from Eastern and the Horn of Africa with the objective of discussing a number of issues for improving overload control in those regions.

(b) Main recommendations

1. Current institutional arrangements for overload control need to be replaced by a self-regulatory system which places the onus for overload control on transport operators and freight forwarders depending on which party has either been responsible for loading the truck or is the principal in terms of the conditions of carriage.
2. It shall be a mandatory requirement for operators to ensure that a COMESA Axle Load Certificate is obtained prior to commencement of the journey.
3. Governments should contract out weighbridge operations to the private sector, leaving them to concentrate on regulatory functions.
- (4) Appropriate structures to be established at country level to enforce and oversee overload control.
5. Enforcement and educational campaigns to be directed at consignors, operators and drivers on the implications of vehicle overloading to the economy.
6. Member states in the COMESA region to draw up a program for implementing the decisions of the Council of Ministers including the following measures:
 - Contracting out the operations of existing weighbridges to the private sector

- Inviting the private sector to invest in weighbridge equipment including the provision of weighbridge services
- Applying overload penalties on defaulting truckers with immediate effect
- Establishing a national committee of all stakeholders in each member state to oversee the implementation of the proposed overload control regime
- Monitoring and certification of trucks to ensure that sufficient axles are in place prior to the issue of operating licenses

12. Workshop on axle load limits, Lilongwe, Malawi August 2000

8.24 (a) Background

1. The workshop was convened by COMESA for member states from the Southern Africa region. This followed on a previous workshop that was held in Nairobi, Kenya for member states from eastern and the Horn of Africa.

8.25 (b) Main recommendations

1. **Harmonization of axle load limits and gross vehicle mass**
 - (a) The 10 ton non-steering single axle, the eighteen ton tandem axle group, the 24 ton tridem axle group and the 56 ton gross vehicle combination must be adopted. COMESA, ECA and SADC should meet and complete their consultations on this recommendation by the end of October, 2000.
 - (b) The penalties for overloading should be borne by either or both the consignor and the transporter and should be commensurate with road damage caused by the over-loaded vehicle.
 - (c) A harmonization program for determining and collecting penalties should be put in place. The penalty fee should be utilized for the improvement of road construction and maintenance.

- (d) Issuance of an Axle Load Limit Compliance Certificate should be encouraged. A certificate should only be issued if the vehicle is within the legal limit.
- (e) Weighbridge authorities should be encouraged to give free passage to vehicles within the legal limit.
- (f) Harmonization of measures, procedures and rules governing the Axle Load Control is recommended.
- (g) Training and sensitization of stakeholders and the setting up of an institutional framework to improve the sector performance should be introduced.
- (h) The requirements for the transportation of hazardous substances should be harmonized.
- (i) COMESA and SADC should discourage the use of the 32 ton four axle group configuration, and
- (j) The choice of transporting goods by road or rail should be determined by the market forces.

2. Management of weighbridges

- (a) Weighbridges should be managed by the private sector while government remains as the regulator. The operator would be paid by the government/roads authority and not be encouraged to charge on an incentive basis.
- (b) Calibration of weighbridges should be standardized and undertaken at least once a year. A tolerance of 5 percent for all weighings should be adopted.
- (c) The approaches to the weighbridges be level and that single axle weighbridges are not used for penalization purposes, and
- (d) Weighbridges should comply with appropriate standards.

3. Standardization of equipment

- (a) Importation of vehicles not suited to the prevailing recommendations is not to be encouraged.

4. Border posts

- (a) The border posts on main routes be open on a 24 hourly basis. The workshop was informed that operators would have no exception to paying a fee to use the border posts after normal working hours.
- (b) One stop border post should be introduced and managed by a private company;
- (c) Weighbridges should be located within the border post area, ports and major loading points;
- (d) A pilot project should be undertaken to investigate the viability of the above recommendations; and
- (e) Networking of all stakeholders (including cross-border traders) should be instituted. .

5. Customs issues

- (a) Installation of computer systems to assist in the customs procedures and documentation within the whole region should be made, and
- (b) If a transit container is axle load limit compliant and seals are all intact it should be allowed to transit through to its destination. Countries should be encouraged to recognize each other's seals.

6. COMESA transit transport facilitation instruments

- (a) COMESA and SADC should refer to and make use of existing documents where possible and harmonize where necessary in the implementation of Transit Transport Facilitation Instruments.

7. Training

- (a) Training in all sectors should be encouraged and harmonized on a regional basis.

13. Draft action plan for implementing the axle load control program, June 2001

8.26 (a) Background

A steering committee comprising COMESA, SATCC, TTCA, IGAD, EAC, ECA and FESARTA requested ECA/SRDC-SA to prepare an Action Plan for assisting member states in the implementation of the Axle Load Control Program, based on the recommendations made during the workshop held in Malawi in August 2000. The main components of the action plan were:

Component 1: Harmonization of measures, procedures and regulations regarding axle load control. Related activities include:

- Analysis of the legal texts and regulations governing the control of axle load limits available in the member states
- Analysis of the relevant of the above texts vis a vis the regulations of SADC/COMESA
- Identification of eventual differences arising from the various legal texts relating to the modalities of implementation of axle load controls in the Eastern and Southern Africa
- Technical analysis on the possibility of introducing the 32 ton axle load configuration
- Preparation of a model legislation on traffic regulations for implementation by member states (designed to be upgraded to regional legal instrument)
- Determination of a rational methodology for determining over-load fines and modalities for collection
- Monitoring of progress achieved

Component 2: Training and management of weighbridges. Related activities include:

- Preparation of guidelines for management of weighbridges
- The development of training manuals for personnel

- Identification of modalities for introducing operation of weighbridges by the private sector
- Exploration of the introduction of joint weighbridge operations and border posts as integral part of the one stop border post proposal
- Preparation of a proposal for mechanism of settlement of disputes arising from the implementation of axle load controls.

Component 3: Standardization of equipment

- Preparation of an inventory of all existing equipment and related facilities
- Assessment of the condition of equipment and its utilization
- Assessment of needs for replacement/refurbishing/extra equipment
- Preparation of guidelines for standardizing the purchase, installation and management of weighbridges
- Preparation of guidelines for establishing region standards for all equipment related to loading and offloading and weighbridges
- Organization of the training workshop

8.27 (b) Way forward

ECA/SRDC-SA to seek funding for procuring consultancy services to undertake the letting of consultants to undertake the above tasks

14. Sub-Saharan Africa overloading and truck taxation survey, August 2004

8.28 (a) Background

The main objective of the survey was to establish the status quo as regards overload control in the SSA with the aim of providing a factual overview of the issues affecting this activity as a basis for recommending the way forward to a more sustainable solution. The survey was undertaken primarily through a questionnaire supplemented by visits to selected countries, mostly in SADC and COMESA. The key issues that were dealt with in the questionnaire included:

- Current approaches to overload control
- Opportunities and obstacles to improved methods of overload control
- Heavy goods vehicle taxation and road user charges
- Countries' views on the way forward to improved overload control

8.29 (b) Conclusions and recommendations

1. Current approaches to overload control

Current approaches to overload control have generally not worked and indications are that they are unlikely to work in future. Past experience has also shown that exclusive reliance on legal load limits and their enforcement may not be enough to ensure effective overload control. New approaches are required, similar in concept to the Road Management Initiative (RMI), in which various elements of sustainability (political, social, institutional, technical, economic, financial and environmental) should be addressed. Moreover, overload control should become an integral part of road management and the focus needs to be shifted from a government enterprise lacking in incentives to partnership with the private sector.

Recommendation 1

Overload control should be viewed more holistically as “Overload Management” and should be pursued in the context of an “Overload Control Management Initiative” (OCMI) in which there is greater cooperation and partnership rather than confrontation between public agencies and transporters.

2. The SADC model legislative provisions

The SADC Model Legislative Provisions (MLP) on Vehicle Loading provide a framework for a new approach to vehicle loading management which consolidates reform efforts carried out in recent years. The MLP take account of international good practice on various aspects of overload control and include a number of trend-setting initiatives that represent a fundamental shift in approach to this activity and, in so doing, respond to the most glaring shortcomings of traditional approaches to overload control. Moreover, they give effect to the SADC Protocol on Transport, Communications and Meteorology which commits member states to implement a harmonized vehicle overloading system.

Recommendation 2

The SADC MLPs should serve as a point of departure for application in all RECs.

3. The Current situation

Despite the concerted effort made by all RECs to control overloading, all countries surveyed indicate that this issue is still a serious problem and, in most cases, has not improved in the past couple decades. Although a number of factors may be responsible for this situation, it is apparent that probably the three most compelling ones are:

- lack of political will and commitment by national governments, despite their expressed intentions to the contrary
- lack of institutional arrangements to “drive” the implementation of the SADC MLP
- insufficient funding in most countries

Recommendation 3

1. Undertake measures to sensitize national governments to the price that their countries are paying for ineffective overload control, including the production of a simple, well-illustrated, appropriately-entitled leaflet on the adverse impact of overloading on the economy.
2. Reactivate the institutional structures agreed at previous SADC regional meetings and reiterated by many of the countries surveyed. These structures include:
 - A National Vehicle Loading Advisory Committees (VELACs) adequately representative of the roads and road traffic sub-sectors
 - A Regional Vehicle Overloading Association (REVOCA) comprising public and private sector representatives to oversee implementation of the regional strategy on overloading control focusing on the regions' road corridors
3. Develop a budget for implementing an integrated Regional System for Overload Control (RESOC) with a matching Action Plan and Financial Plan and sources of funding (governments, donors, private sector, etc.) for soliciting support from key stakeholders.
4. Make effective overloading donor conditionality for any financial assistance for new road projects.

4. Regional coordination

Although the SADC MLP provide a regional vision for national improvement of overload control, lack of appropriate institutional arrangements to “drive” the process has resulted in uncoordinated approaches at country level. Moreover, agreements reached several years ago on how best to deal with implementation of the MLP have lost momentum and, as a result, very little progress has been made in improving overload control in many countries.

Recommendation 4

Through REVOCA, promote the regional effectiveness of overload control and oversee the implementation of an integrated Regional System for Overload Control (RESOC) including:

- Harmonization of measures, procedures and regulations regarding axle load control
- Standardization of equipment
- Coordinated network of standardized weighbridges strategically and equitably spread over the Regional Trunk Road Network.

5. Training and management

The management, operation and maintenance of modern weighbridge scales has increased in complexity in recent years and requires a collective range of skills of a managerial, supervisory, technical, legal and mechanical nature. This requires a cadre of well-educated and properly trained staff who are adequately remunerated. Although lack of adequate training has been cited by many countries as a major problem, the enhanced level of training currently required to undertake modern-day weighbridge operations does not appear to be fully appreciated.

Recommendation 5

Develop standardized guidelines on training of personnel for management and operation of weighbridges with related certification and accreditation schemes.

6. Standardization of equipment

A number of countries are embarking on the procurement, installation and operation of weighbridges along their strategic routes. Unfortunately, in the absence of standardized guidelines there have been a number of instances where countries have purchased the wrong kind of equipment or the equipment installation has been inadequate for the function required... Moreover, operation of non-standardized equipment and weighing operations has resulted in differences in weighing methods, the conditions under which vehicles are weighed and the way in which the loads are recorded in various countries.

Recommendation 6

Prepare regional guidelines aimed at standardizing the procurement, installation and operation of weighbridges.

7. On-going initiatives

SADC and COMESA have collaborated in recent years on various initiatives to improve the effectiveness of overload control in their RECs. One such initiative entails the implementation of pilot scale projects to evaluate the impact of involving the private sector in weighbridge operations, including selection of weighbridge types, computerization of operations and determination of the fee structure for overloading offences.

Recommendation 7

On-going initiatives that have been agreed at REC level and are at an advanced stage of planning, such as the pilot scale projects, should be given priority consideration for implementation.

15. Cross-Border Overload Control Project. August 2004

8.30 (a) Background

As part of its assistance to Southern African region, the Southern African Global Competitiveness Hub (SAGCH) of the USAID Regional Centre for Southern Africa (RCSA) supported the implementation of a pilot project for a Cross-Border Overload Control System (CBOCS) at Martin's Drift/Groblers Bridge border post between Botswana and South Africa. The project was implemented in December 2004.

8.31 (b) Findings, conclusions and recommendations*Findings*

- The CBOCS is operating generally in compliance with the minimum requirements of the system design.

- The incidence of overloaded vehicles in excess of the 5 percent tolerance has reduced dramatically from a mean monthly value of 8.2 percent to 2.9 percent. There has also been a four-fold increase in the number of vehicles weighed.

Conclusions

- The pilot project has been a success in that it has achieved the main objective set initially by stakeholders – the reduction of overloading at the Groblers Bridge/Martins Drift border post.
- This success of the CBOCS has been achieved:
 - with benefits to Customs in terms of minimizing the scope for under-declaration of goods on a mass basis and without additional delays to vehicles
 - Without significant additional delays to commercial vehicles

Recommendations

The CBOCS pilot project should, in principle, be rolled out to the other border posts along the TKC and NS corridors. However, the prior support and commitment of national stakeholders from the countries involved, namely Botswana, South Africa and Zambia is required.

16. Workshop on overload control project, February 2007

8.32 (a) Background

This workshop was held in Botswana on 15th and 16th February 2007. The workshop was organized by the Association of Southern African National Roads Agencies (ASANRA) to enable practitioners involved in overload control in their respective countries to share their country experiences and good practice on the subject. This information was meant to provide an input to the study being conducted by the Sub-Saharan Africa Transport Policy Program (SSATP) through the Regional Economic Commu-

ities-Transport Coordination Committee (REC-TCC). Other objectives of the workshop, at which five SADC countries were represented, were to:

- Update delegates on the current practices relating to the Overload Control
- Share knowledge on weighbridge infrastructure
- Share knowledge on how to apply latest overload control initiatives

8.33 (b) Main outputs

1. Examples of good practice included:
 - Heavy Vehicle Accreditation Scheme in South Africa
 - Involvement of the private sector in upgrading of overload control systems and weighbridge infrastructure in the Western Cape, South Africa.
 - General overload control operations in Namibia which are modeled on the SADC MoU on Vehicle Loading (except for decriminalization of overloading offences). Which have resulted in a significant reduction in the percentage of overloaded heavy vehicles from 28.9 percent in 1998 for overload within 5 percent tolerance to 10 percent in 2005?
 - The involvement of the private sector in the upgrading of the Western Cape overloading control systems via a successful PPP model.
2. Other issues
 - a) The need for harmonization of the SADC/COMESA recommended vehicle load limits as agreed at the Malawi workshop in 2000 when COMESA agreed to adopt the SADC limits (this has apparently still not happened).
 - b) ASANRA now has a key role to play in coordinating overload control in the region as a champion and driver of the implementation of the SADC MoU on Vehicle Loading.
 - c) There is an urgent need for regional harmonized training in overload control in terms of a common syllabus for all mem-

bers' states. A qualification to the Diploma level should be aimed for as is currently offered in South Africa.

- d) A regional accreditation scheme needs to be put in place to guide member states in the calibration of weighbridge equipment. This activity was being carried out at widely varying intervals ranging from every three months in some countries to every 24 months in others.
- e) Some member states had never seen the SADC MoU on Vehicle Loading! This document was to be made available by ASANRA to all members stated via its website.